

# Service Manual

Stereo Cassette Deck

Cassette Deck

System: SC-CH770

**DD DOLBY B NR** \*1

## RS-CH770

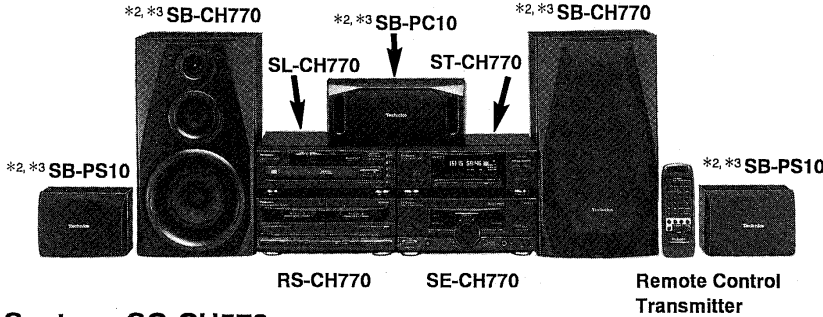

Colour

(K) : Black

### Areas

Suffix for Model No.	Area	Colour
(E)	Europe, Asia, Latin America, Middle East, Africa and Oceania	(K)

System: SC-CH570

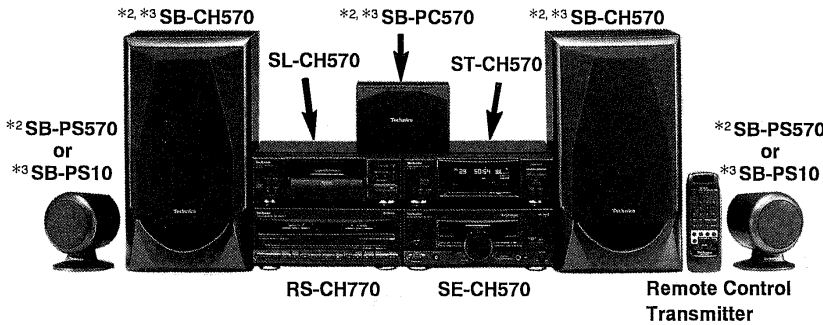

\*1 : Dolby noise reduction manufactured under license from Dolby Laboratories Licensing Corporation.  
 "Dolby" and the double-D symbol are trade marks of Dolby Laboratories Licensing Corporation.

## AR-2 MECHANISM SERIES Specifications (IHF '78)

### ■ Cassette Deck Section

Deck system	Stereo cassette deck
Track system	4-track, 2-channel
Recording system	AC bias
Bias frequency	100 kHz
Erasing system	AC erase
<b>Heads</b>	
DECK 1	Playback head (Permalloy) × 1
DECK 2	Recording/Playback head (Permalloy) × 1
	Erasing head (Double-gap ferrite) × 1
<b>Motors</b>	
DECK 1, 2	Capstan drive (DC servo motor) × 1
Tape speed	4.8 cm/sec.
Wow and flutter	0.16% (WRMS)
Fast forward and rewind times	Approx. 110 seconds with C-60 cassette tape

### Frequency response (Dolby NR off)

TYPE I (NORMAL)	20 Hz-16 kHz (DIN)
TYPE II (HIGH)	20 Hz-16 kHz (DIN)
TYPE IV (METAL)	20 Hz-16 kHz (DIN)
S/N (signal level = max recording level, TYPE II type tape)	
NR off	56 dB (A weighted)
Dolby NR B on	66 dB (A weighted)
<b>Input sensitivity and impedance</b>	
REC (IN)	400 mV/23 kΩ
<b>Output voltage and impedance</b>	
PLAY (OUT)	280 mV/360 Ω

### ■ General

Dimensions (W × H × D)	270 × 118.5 × 269.5 mm
Weight	1.9 kg

### Notes:

Specifications are subject to change without notice.  
 Weight and dimensions are approximate.

System	Tuner/sound processor	Compact disc player	Amplifier	Cassette deck	Front speakers	Center speaker	Surround speakers
SC-CH770	ST-CH770	SL-CH770	SE-CH770	RS-CH770	*2, *3 SB-CH770	*2, *3 SB-PC10	*2, *3 SB-PS10
SC-CH570	ST-CH570	SL-CH570	SE-CH570		*2, *3 SB-CH570	*2 SB-PT570	
						*2 SB-PC570	*2 SB-PS570
						*3 SB-PT570A	
					*3 SB-PC570	*3 SB-PS10	

\*2 For Europe area: ..... Made in PAES

\*3 Except for Europe area: ..... Made in NABEL

# Technics®

© 1996 Matsushita Electric Industrial Co., Ltd.  
 All rights reserved. Unauthorized copying and distribution is a violation of law.

**⚠ WARNING**

This service information is designed for experienced repair technicians only and is not designed for use by the general public. It does not contain warnings or cautions to advise non-technical individuals of potential dangers in attempting to service a product. Products powered by electricity should be serviced or repaired only by experienced professional technicians. Any attempt to service or repair the product or products dealt with in this service information by anyone else could result in serious injury or death.

**■ Contents**

	Page		Page
Location of Controls .....	2	Wiring Connection Diagram .....	26
Operation Check and Main Component Replacement Procedures .....	3~12	Function of IC Terminals .....	27
Service Mode Function of Cassette Mechanism .....	13, 14	Block Diagram .....	28, 29
Measurements and Adjustments .....	15~17	Replacement Parts List .....	30~34
Schematic Diagram .....	18~23	Cabinet Parts Location .....	35
Printed Circuit Board Diagram .....	24~26	Mechanism Parts Location .....	36, 37

**NOTE:**

Refer to the service manual for Model No. SE-CH770 (ORDER No. AD9603055C8) or SE-CH570 (ORDER No. AD9603054C8) for information on "Accessories", "Stacking the Components", "Connections" and "Packaging".

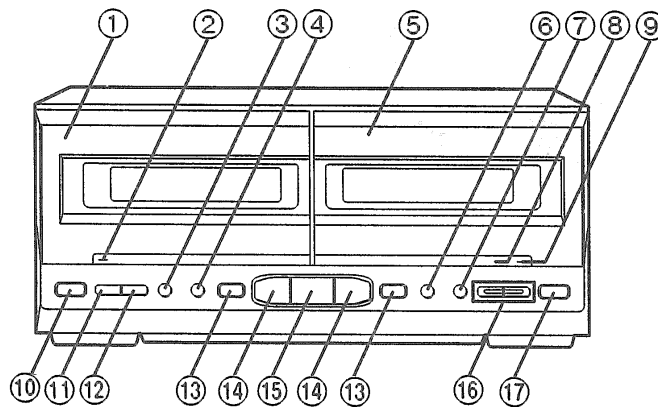
**■ Location of Controls**

- ① Deck 1 cassette holder
- ② Deck 1 indicator (DECK 1)
- ③ Deck 1/deck 2 select button (DECK 1/2)
- ④ Reverse mode select button (REV MODE)
- ⑤ Deck 2 cassette holder
- ⑥ Dolby noise reduction button (DOLBY NR)
- ⑦ Record pause button (● REC PAUSE)
- ⑧ Record pause indicator (REC PAUSE)
- ⑨ Deck 2 indicator (DECK 2)
- ⑩ Deck 1 cassette holder open button (▲ OPEN)
- ⑪ Counter reset button (RESET)
- ⑫ Counter display button (DISPLAY)
- ⑬ Fast forward/rewind/tape program sensor buttons (◀◀, ▶▶)
- ⑭ Playback buttons and indicators (<, >)
- ⑮ Stop button (□)
- ⑯ Tape edit buttons (TAPE EDIT, NOR, HIGH)
- ⑰ Deck 2 cassette holder open button (▲ OPEN)

## OPERATION CHECKS AND MAIN COMPONENT REPLACEMENT PROCEDURES

### NOTE

1. This section describes procedures for checking the operation of the major printed circuit boards and replacing the main components.
2. For reassembly after operation checks or replacement, reverse the respective procedures. Special reassembly procedures are described only when required.
3. Select items from the following index when checks or replacement are required.
4. Illustrated screws are equivalent to actual size.
5. Refer the parts No. on the page of "Main Component Replacement Procedures", if necessary.

### Contents

•Checking Procedure for each P.C.B.		Page.
1. Checking for the main P.C.B. and power supply P.C.B..	.....	3,4.
2. Checking for the operation P.C.B..	.....	5,6.
•Main Component Replacement Procedures		
1. Replacement for the cassette lid ass'y.	.....	7.
2. Replacement for the cassette holder.	.....	7.
3. Replacement for the motor ass'y, capstan belt and winding belt.	.....	8~11.
4. Replacement for the plunger ass'y and the parts mounted on mechanism P.C.B..	.....	11,12.
5. Replacement for the head block and pinch roller ass'y.	.....	12.

### Checking Procedure for each P.C.B.

#### 1. Checking for the main P.C.B. and power supply P.C.B.

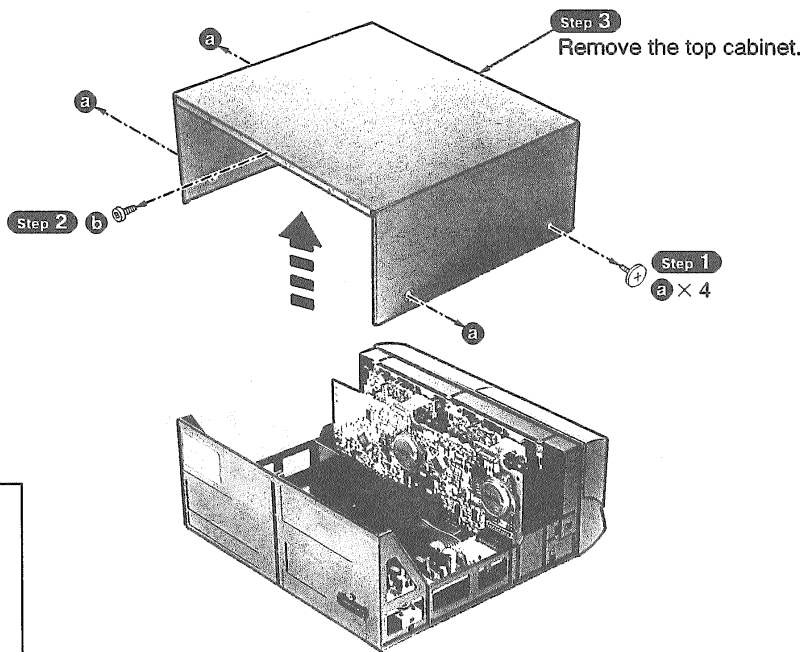

[RHD30007-K1]



[XTBS3+8JFZ1]

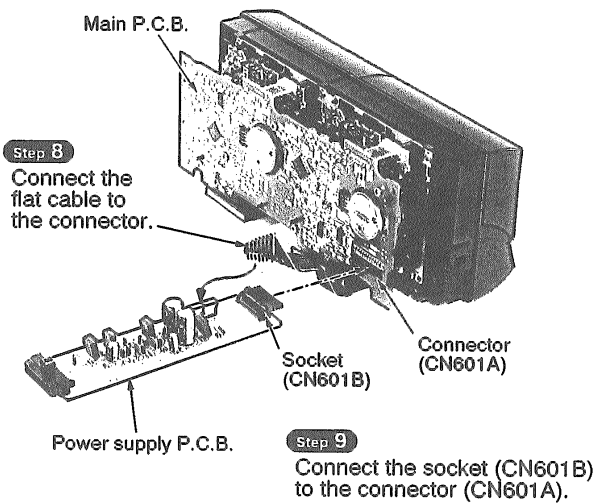
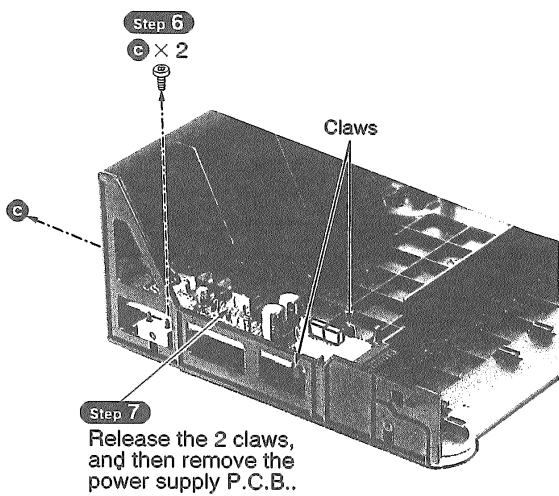
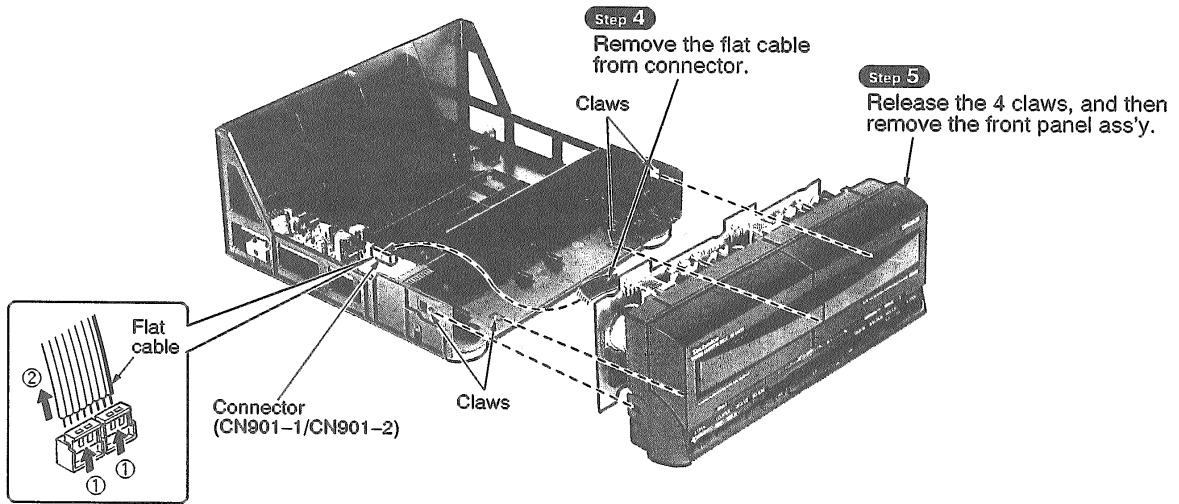

• Check the main P.C.B. and power supply P.C.B. as shown below.

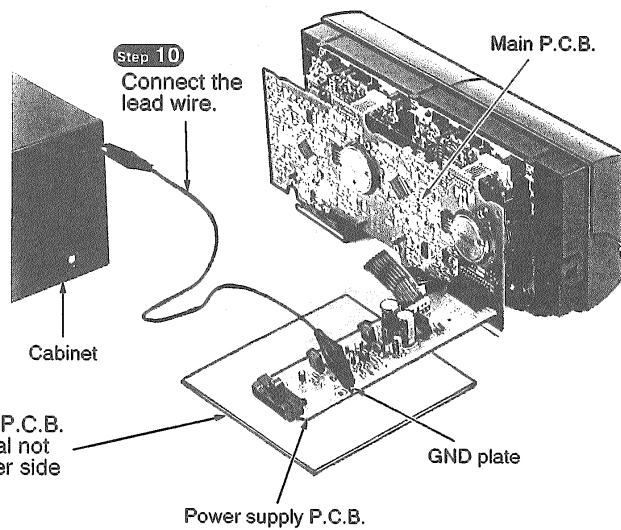

**NOTE**

Place the power supply P.C.B. on the insulation material not to short-circuit the solder side of power supply P.C.B..



[XTBS3+8JFZ1]

**2. Checking for the operation P.C.B.**

• Follow the **Step 1** ~ **Step 7** of the item 1 in checking procedure for each P.C.B. on pages 3 and 4.

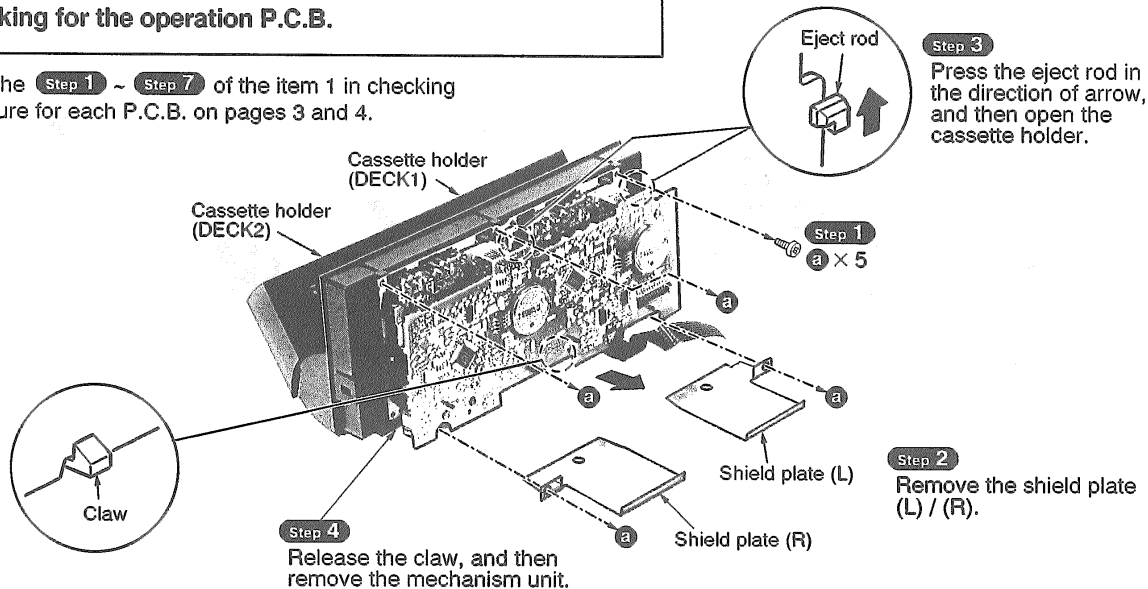

**Step 5**  
Remove the cassette lid ass'y in the direction of arrow.

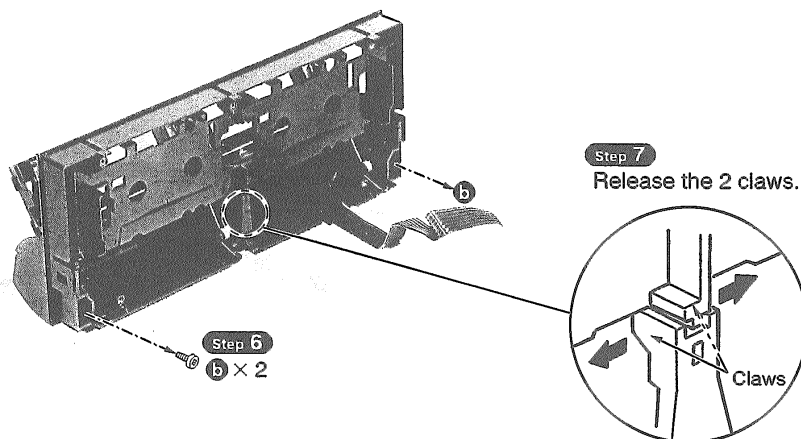
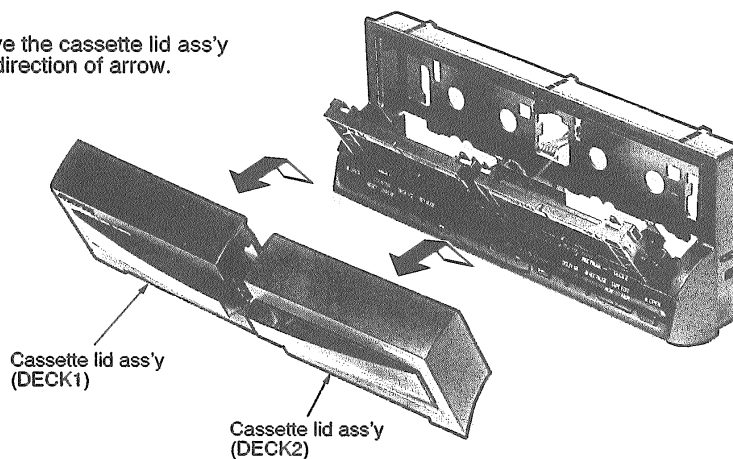

- a (Black)  
[XTB3+10JFZ]
- b  
[XTBS26+10J]

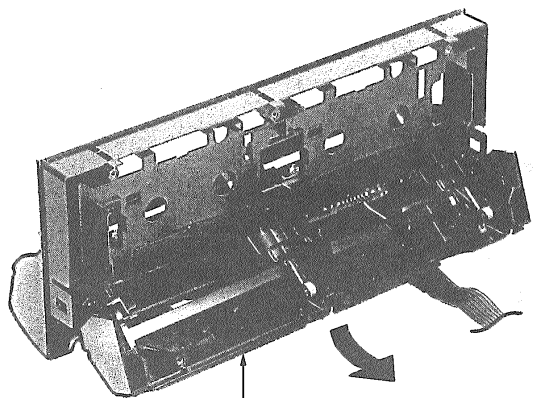

**Step 8**  
Remove the deck mecha frame  
in the direction of arrow.

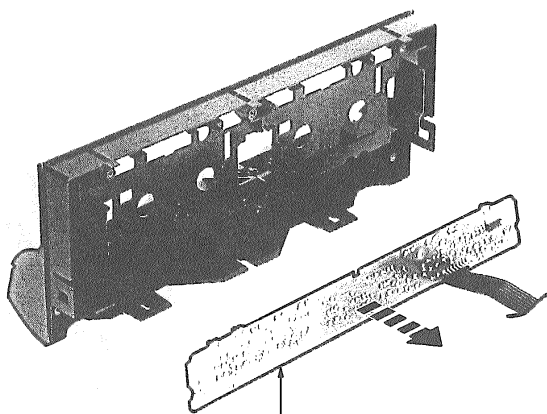

**Step 9**  
Remove the operation P.C.B..

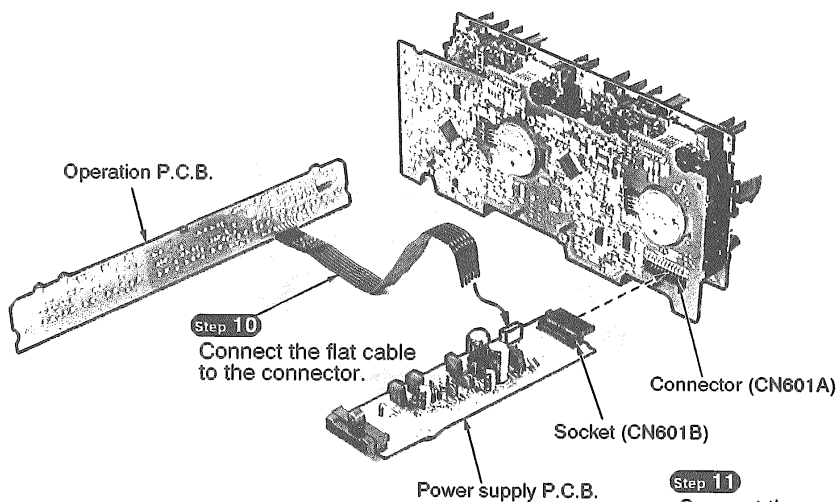

**Step 10**  
Connect the flat cable  
to the connector.

**Step 11**  
Connect the socket (CN601B)  
to the connector (CN601A).

• Check the operation P.C.B. as shown below.

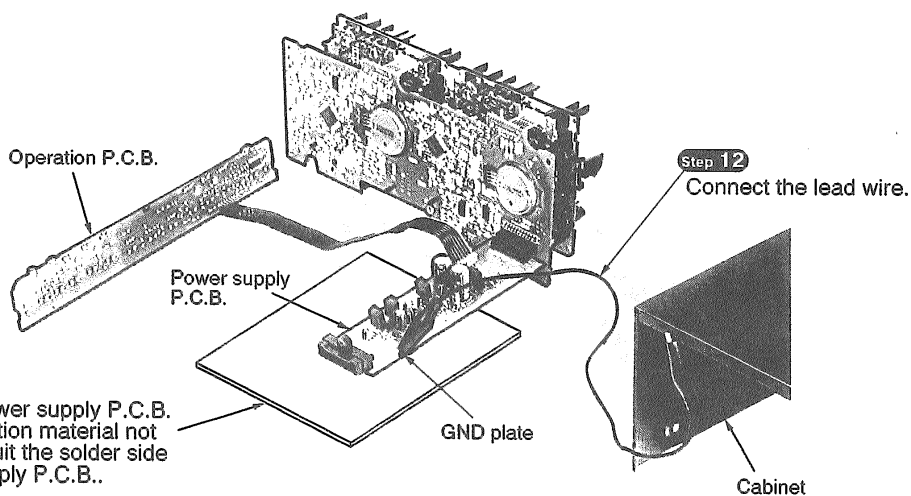

**NOTE**  
Place the power supply P.C.B.  
on the insulation material not  
to short-circuit the solder side  
of power supply P.C.B..

## ■ Main Component Replacement procedures

### 1. Replacement for the cassette lid ass'y

- Follow the **Step 1** ~ **Step 3** of the item 1 in checking procedure for each P.C.B. on page 3.

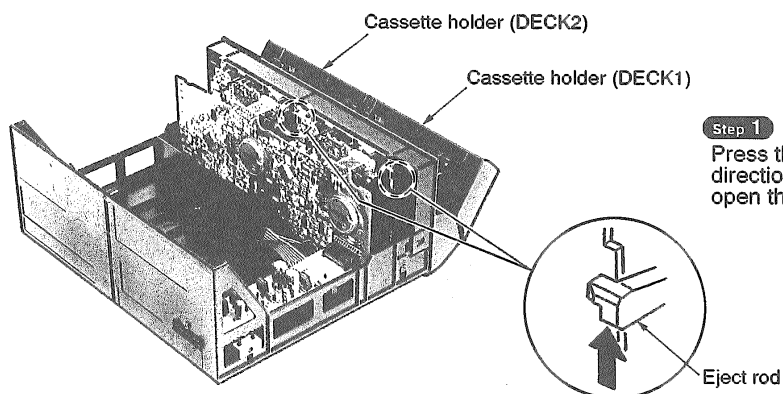

**Step 1**  
Press the eject rod in the direction of arrow, and then open the cassette holder.

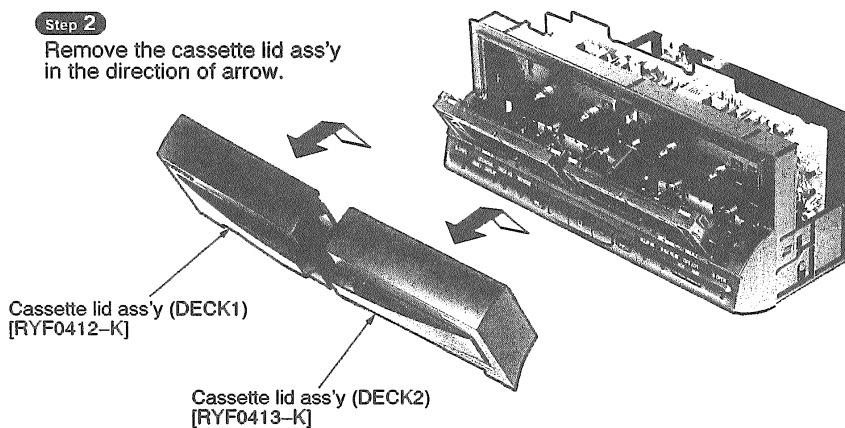

**Step 2**  
Remove the cassette lid ass'y in the direction of arrow.

### 2. Replacement for the cassette holder

- Follow the **Step 1** ~ **Step 5** of the item 1 in checking procedure for each P.C.B. on pages 3 and 4.
- Follow the **Step 1** ~ **Step 8** of the item 2 in checking procedure for each P.C.B. on pages 5 and 6.

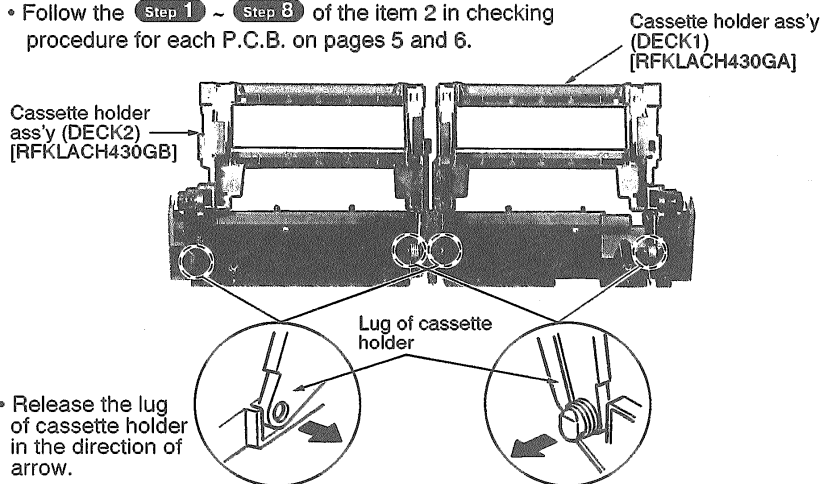

- Release the lug of cassette holder in the direction of arrow.

#### ■ Open spring installation

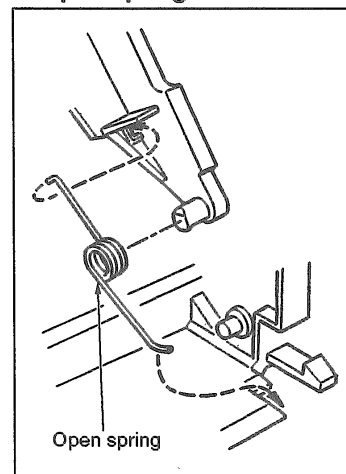

### 3. Replacement for the motor ass'y, capstan belt and winding belt

- Follow the **Step 1** ~ **Step 5** of the item 1 in checking procedure for each P.C.B. on pages 3 and 4.
- Follow the **Step 1** ~ **Step 4** of the item 2 in checking procedure for each P.C.B. on page 5.

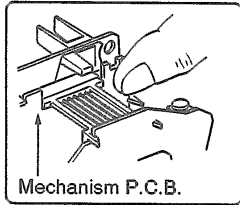

**NOTE**

When removing the mechanism control P.C.B., remove it with holding the mechanism P.C.B. by finger.

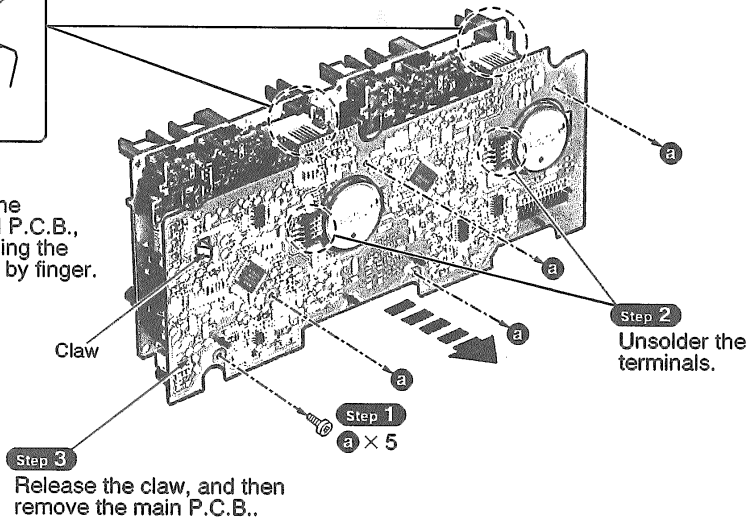

**NOTE**

Handle the connector with care so that the shape of terminals different from others.

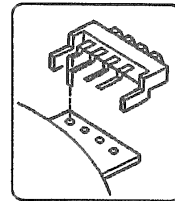

**NOTE**

The illustration below shows DECK2 mechanism. For DECK1 mechanism, perform the same procedure as DECK2.

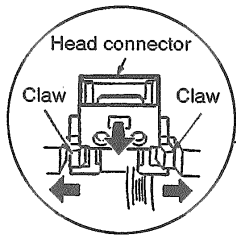
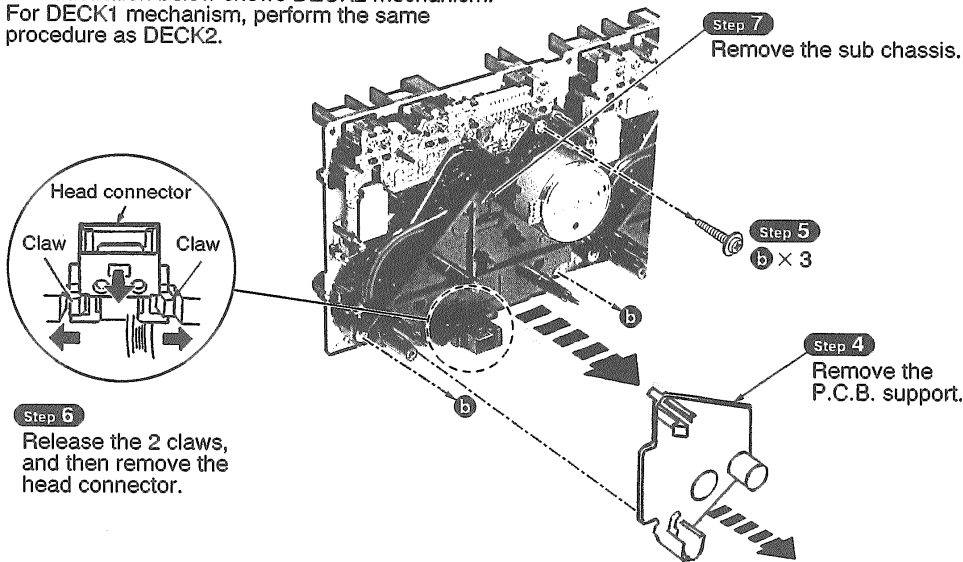

**Step 6**

Release the 2 claws, and then remove the head connector.

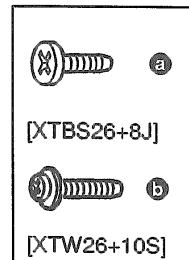



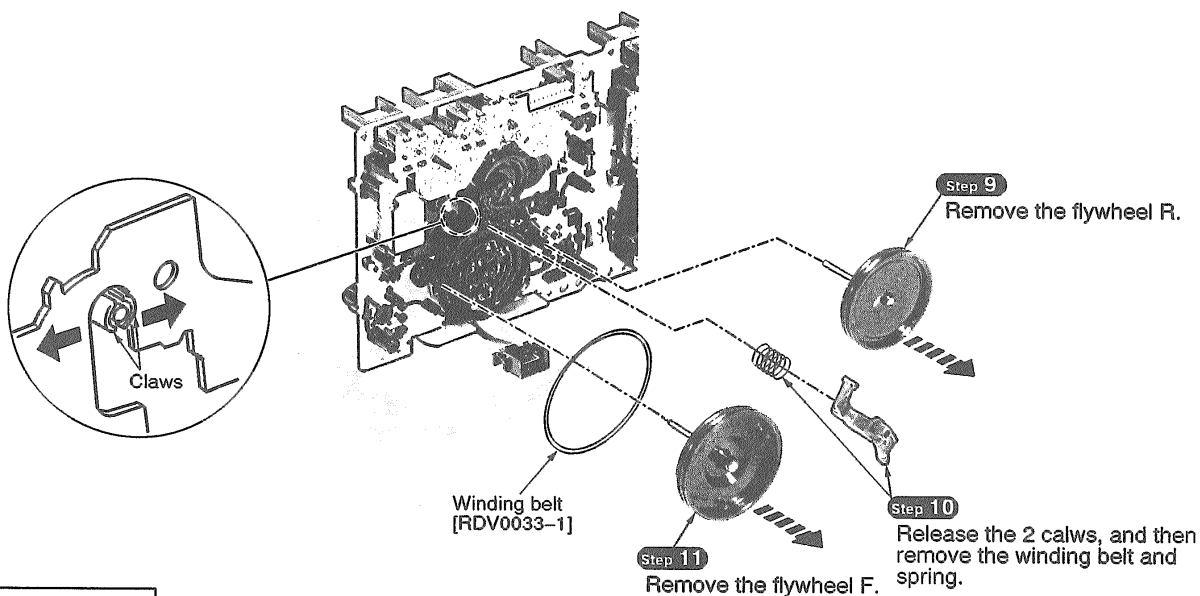
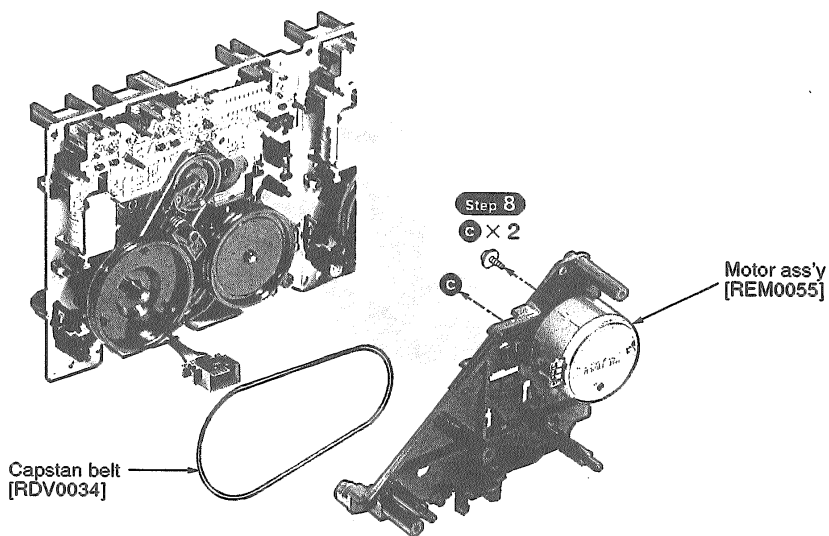

**Installing the belt**

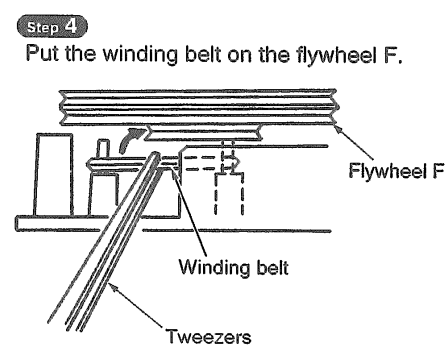
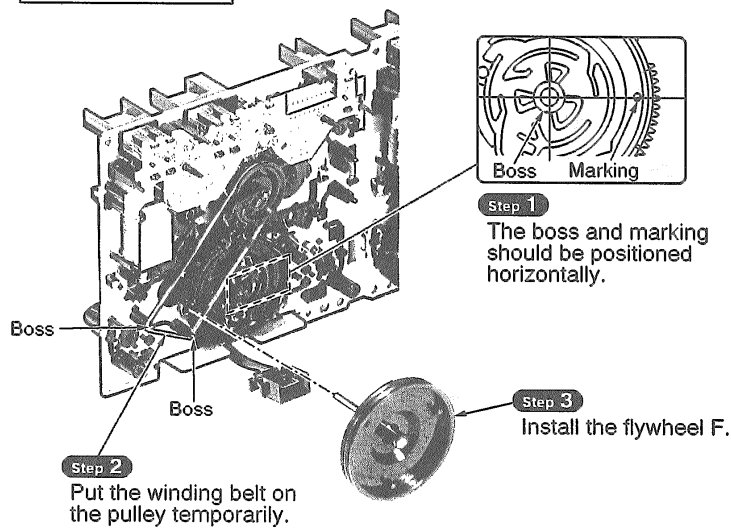

**NOTE**  
Take care not stick the grease on the belt.

**NOTE**

The winding lever should be positioned as shown below.

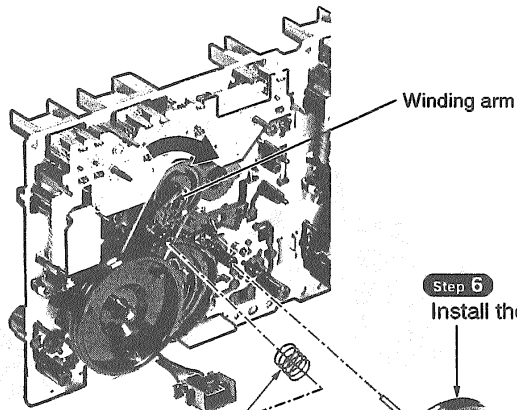
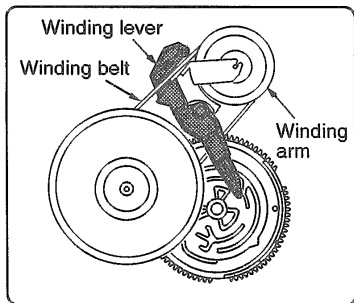

**Step 6**  
Install the flywheel R.

**Step 5**  
Install the winding lever and spring while pressing the winding arm in the direction of arrow.  
(The winding lever must be inserted completely and latched with claws.)

**Step 7**  
Put the capstan belt A temporarily as shown below.

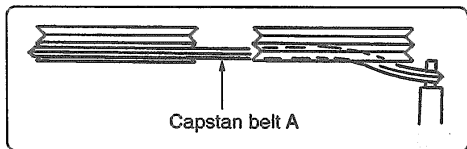

(Side view)

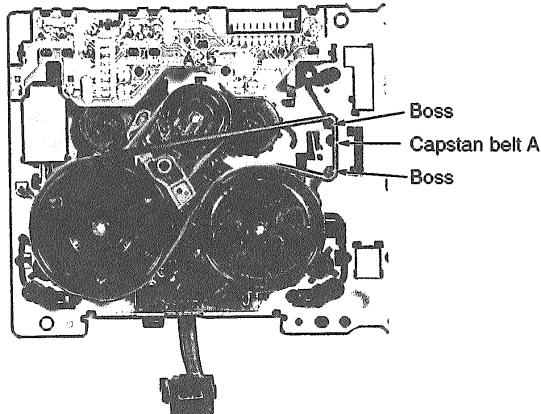

**Step 8**  
Install the sub chassis to the mechanism, and then tighten screws.

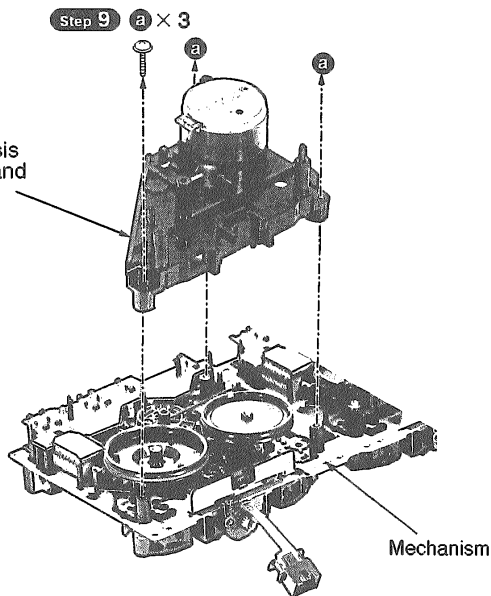

[XTW26+10S]

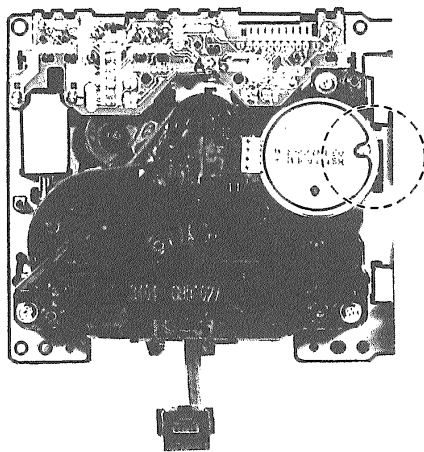

Step 10

Put the capstan belt on the motor ass'y pulley.

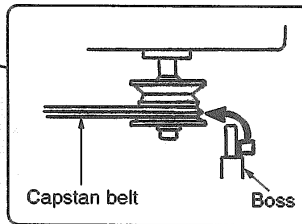

**4. Replacement for the plunger ass'y and the parts mounted on mechanism P.C.B.**

- Follow the Step 1 ~ Step 5 of the item 1 in checking procedure for each P.C.B. on pages 3 and 4.
- Follow the Step 1 ~ Step 4 of the item 2 in checking procedure for each P.C.B. on page 5.
- Follow the Step 1 ~ Step 3 of the item 3 in main component replacement procedures on page 8.

**NOTE**

The illustration below shows DECK2 mechanism. For DECK1 mechanism, perform the same procedure as DECK2.

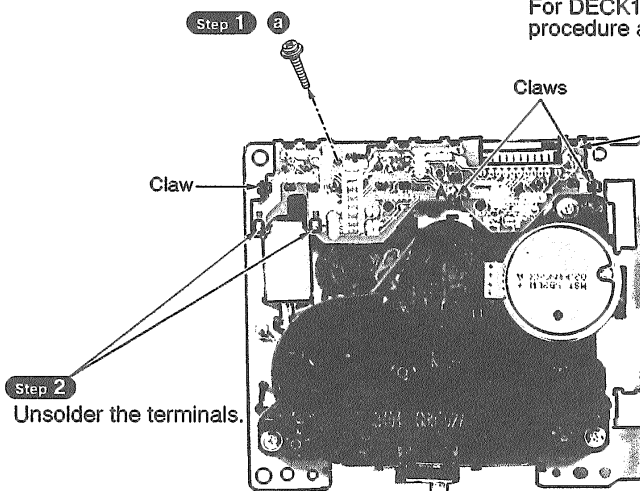

Step 3

Release the 3 claws, and then remove the mechanism P.C.B..

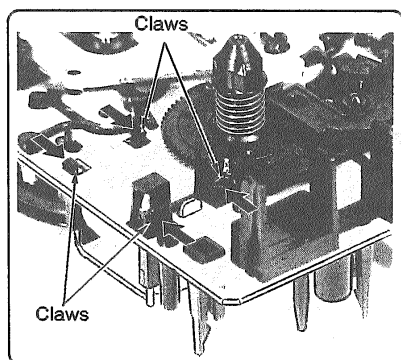
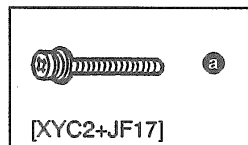

Step 4 Release the 4 claws.

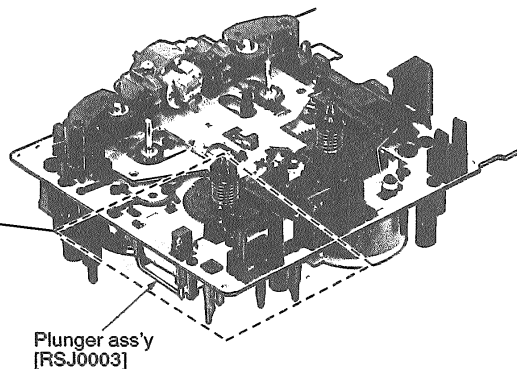

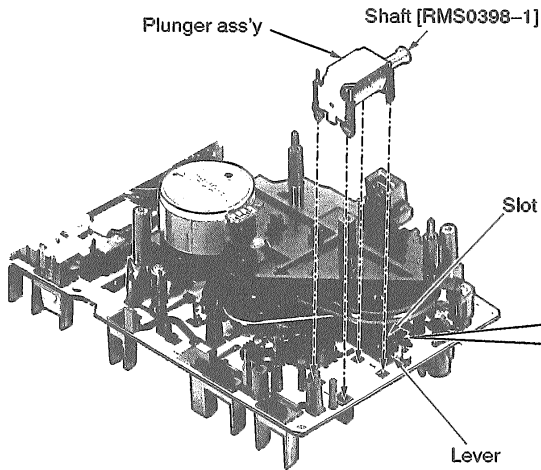

**NOTE**

Notice for installing the plunger ass'y  
 • The shaft of plunger ass'y should be aligned with the slot of lever.

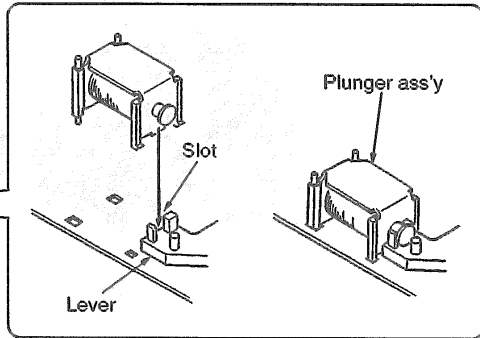

**5. Replacement for the head block and pinch roller ass'y**

- Follow the **Step 1** ~ **Step 5** of the item 1 in checking procedure for each P.C.B. on pages 3 and 4.
- Follow the **Step 1** ~ **Step 4** of the item 2 in checking procedure for each P.C.B. on page 5.
- Follow the **Step 1** ~ **Step 3** of the item 3 in main component replacement procedures on page 8.

**NOTE**

The illustration below shows DECK2 mechanism. For DECK1 mechanism, perform the same procedure as DECK2.

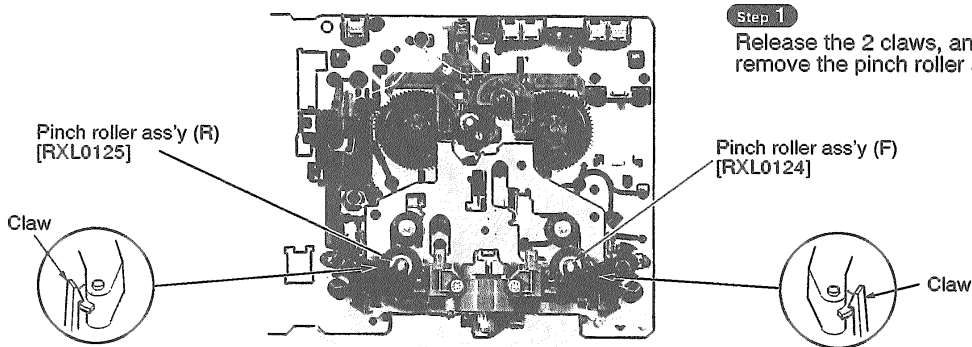

**Step 1**

Release the 2 claws, and then remove the pinch roller ass'y (R),(F).

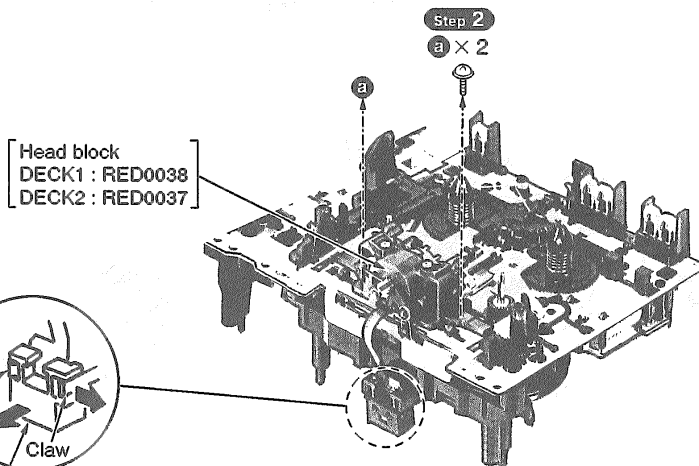

**Step 3**

Release the 2 claws, and then remove the head connector.

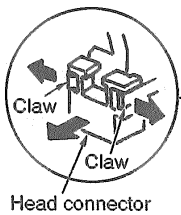

[XTW2+5L]

## ■ Service Mode Function of Cassette Mechanism

This unit is equipped with a service mode function of cassette mechanism using the LED indicators [R. PLAY (◀), F. PLAY (▶)] and cassette holder illuminations [DECK 1, DECK 2]. Use this function during maintenance to check faults of the items below.

### ● Cassette tapes to be prepared

- Metal tape: Recorded music tape with only one erase-prevention tab intact (use middle portion of tape).  
 Normal tape: Recorded music tape with both erase-prevention tabs intact (use middle portion of tape).  
 CrO2 tape: }

### ● Selecting Service Mode

1. Turn on the power to the unit. (If RS-CH770 unit is removed from system, turn it on according to the procedure on page 15.)
2. Check that no tape is inserted in the cassette deck.  
Press the DOLBY NR button for about 2 seconds, and keep pressing it, also press the STOP button for about 2 seconds. (Service mode cannot be selected with a tape inserted in the cassette deck.)
3. The LED indicator for REC PAUSE flashes, the service mode has been activated.

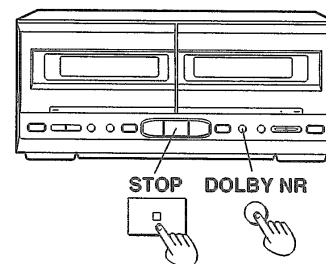

### ● Deck 1 Mechanism Check

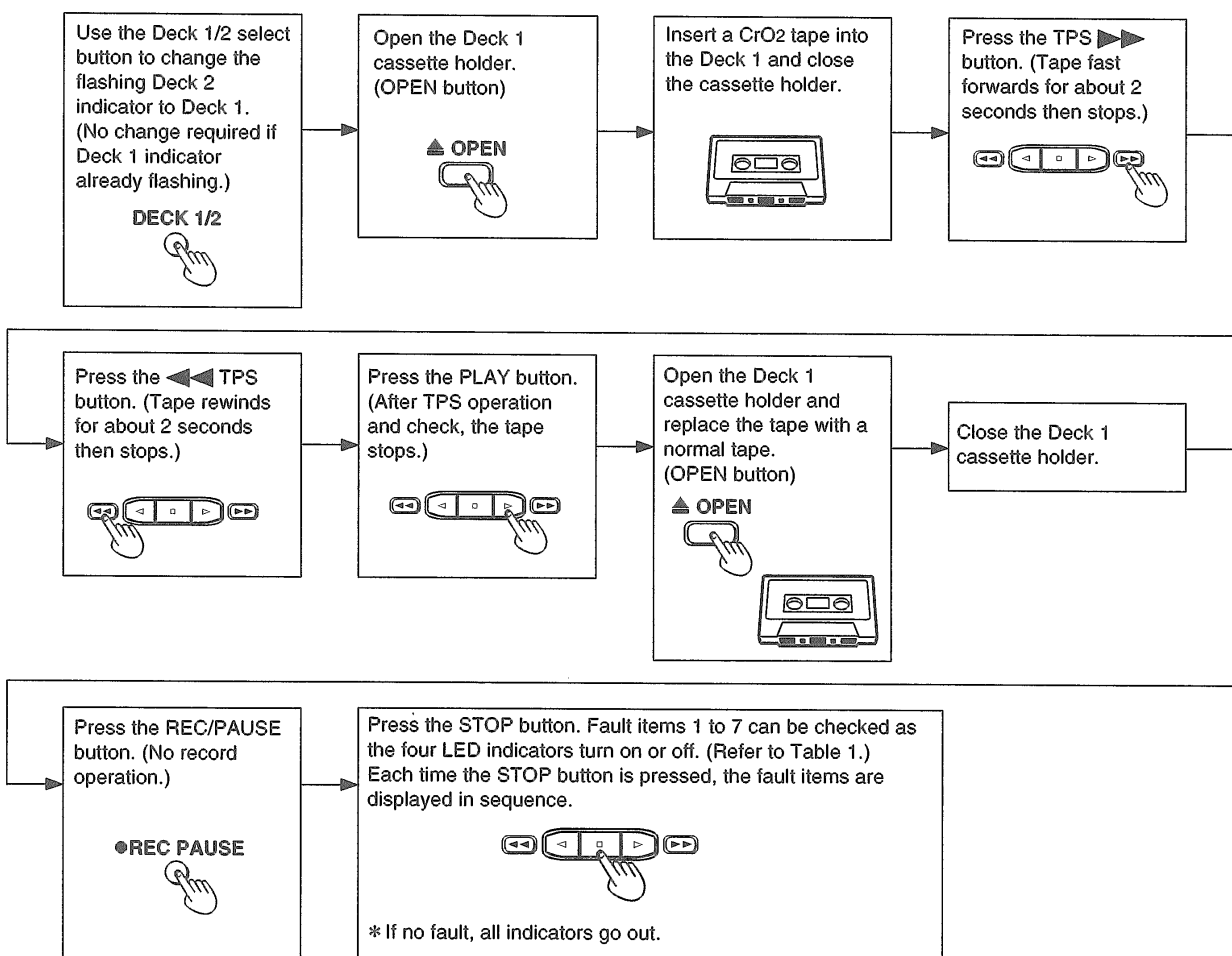

**Table 1: Service Mode Diagnostic Items**

No.	LED indicator and illumination status (on/off)				Fault location
	◀	▶	DECK 1	DECK 2	
1.	—	—	—	●	MODE detect switch
2.	—	—	●	—	REC prevention switch
3.	—	—	●	●	Half detect switch
4.	—	●	●	—	CrO2 tape detect switch
5.	—	●	●	●	Metal tape detect switch
6.	●	—	—	—	Reel pulse detect system (Hall IC, etc.)
7.	●	—	—	●	TPS operation

**Notes:**

“●”: ON

“—”: OFF

\* If no fault, all indicators go out.

**• Deck 2 Mechanism Check**

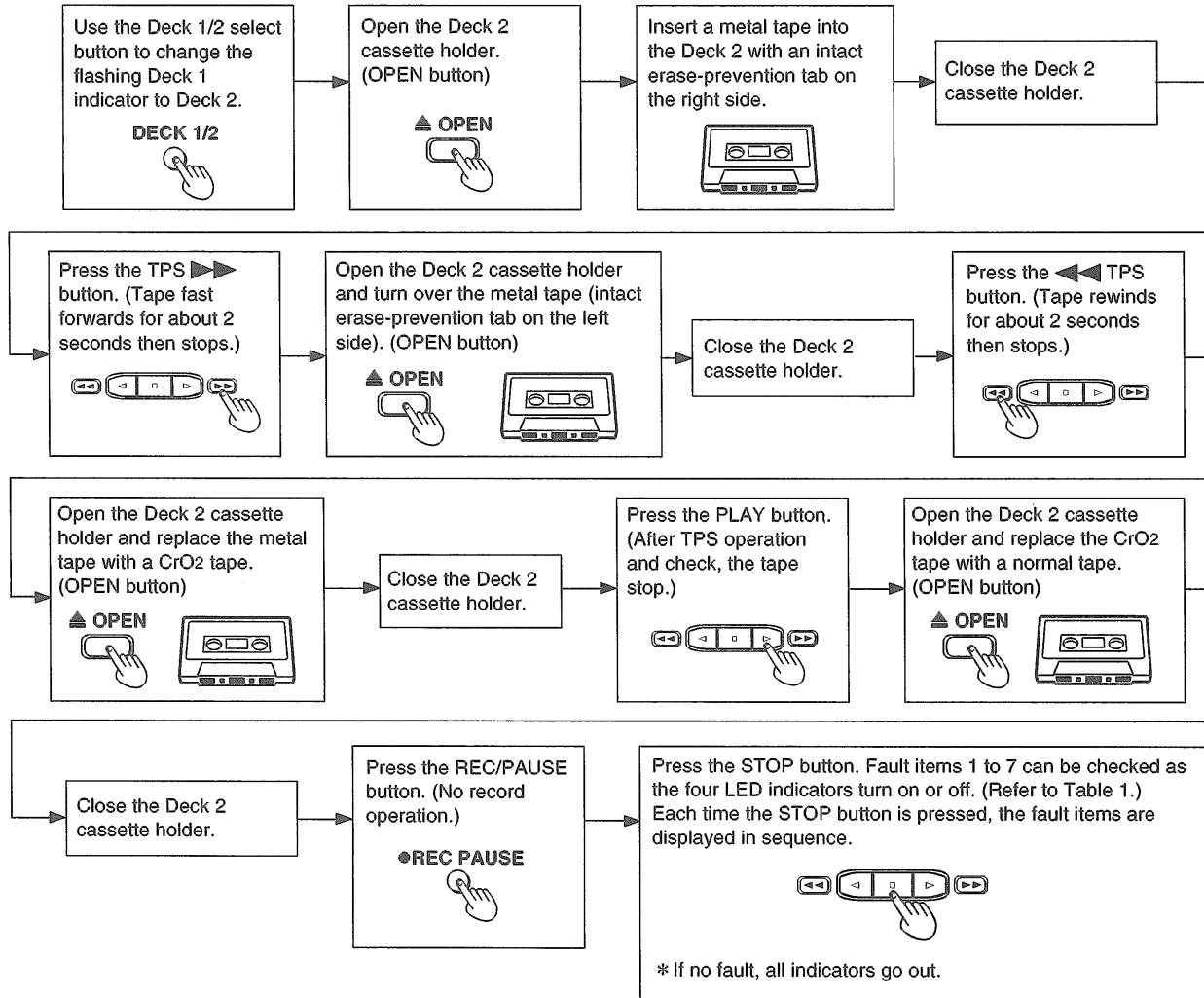

**• Exiting Self-Check Mode**

1. Press the STOP button for more than 6 seconds. (Diagnostic contents stored in memory for both Deck 1 and 2 are erased.)
2. Remove the cassette tape from the cassette holder.
3. Turn off the unit.

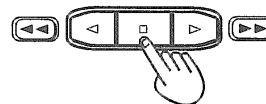

## ■ Measurements and Adjustments

This unit RS-CH770 is designed to operate on power supplied from the Amplifier (SE-CH570 or SE-CH770) through Tuner/Sound Processor (ST-CH570 or ST-CH770).

When connecting the unit to other system components, do not connect to the Amplifier (SE-CH570 or SE-CH770) directly. Be sure to connect this unit through the Tuner/Sound Processor (ST-CH570 or ST-CH770).

When operating the unit RS-CH770 alone for testing and servicing, without having power supplied from the Amplifier (SE-CH570 or SE-CH770) and the Tuner/Sound Processor (ST-CH570 or ST-CH770), use the following method.

### ● To Supply Power Source

Apply 11 V AC power to test points between **TP601** and **TP602** (GND), and **TP603** and **TP602** (GND).

**Notes:** When operated alone, this unit automatically enter the TEST mode, causing either the DECK1 or DECK2 indicators to blink.

In TEST mode, please make sure whether the Dolby B indication is on or off by the illumination of DECK 1 cassette holder is lighted on or off. (DECK 1 illumination is lighted on: Dolby ON, illumination is lighted off: Dolby OFF)

### ● To Check Signals

Connect an oscilloscope or a built-in amplifier speaker between line output for L-ch (**TP607**) and **A.GND**, and line out for R-ch (**TP608**) and **A.GND** and check if the signals are outputting from this unit.

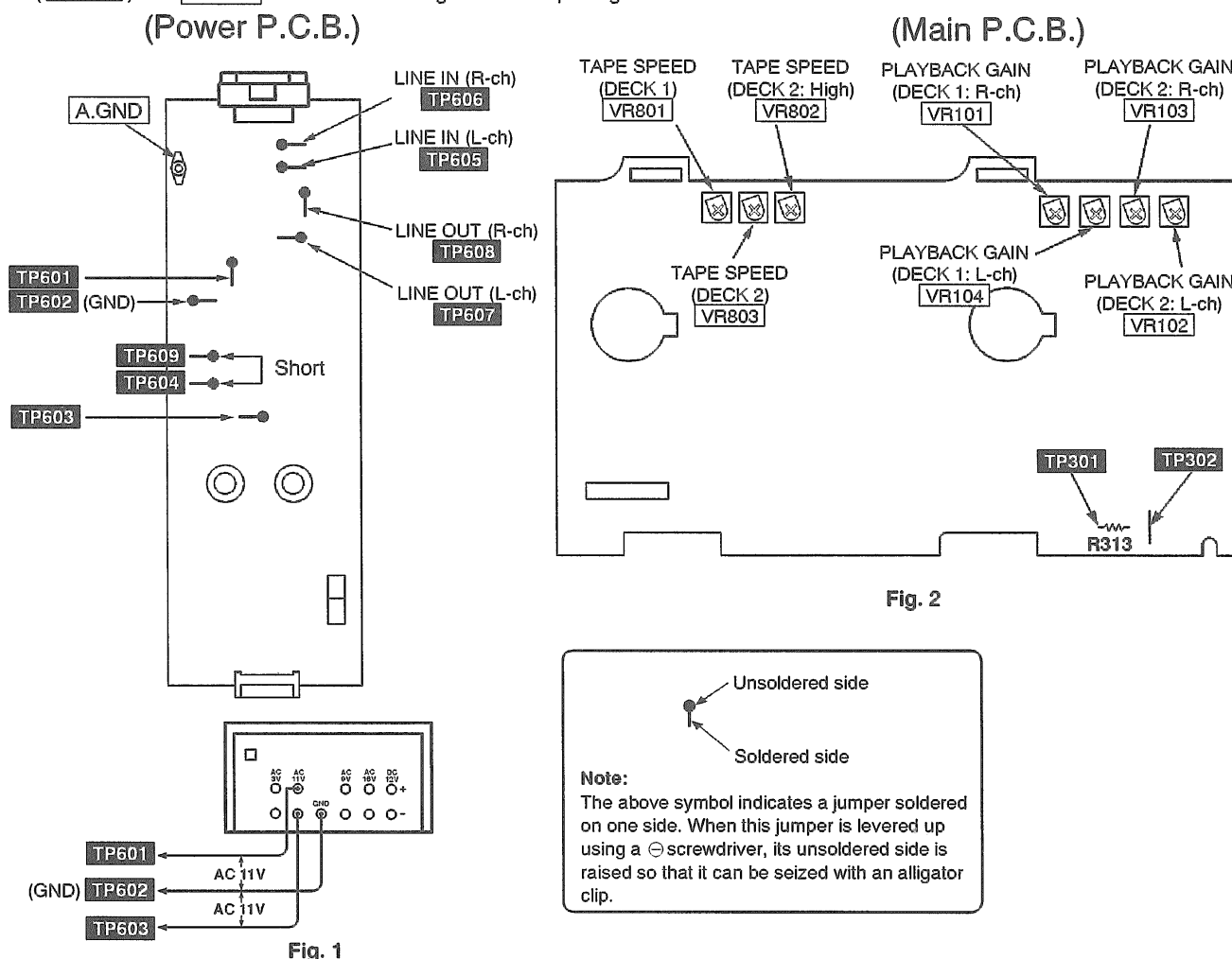

### Measurement Condition

- Dolby NR switch; OFF
- Make sure heads are clean.
- Make sure capstan and pressure roller are clean.
- Judgeable room temperature 20±5°C (68±9°F)

### Measuring instrument

- EVM (Electronic Voltmeter)
- AF oscillator
- Digital frequency counter

### Test tape

- Head azimuth adjustment (8 kHz, -20 dB); QZZCFM
- Tape speed adjustment (3 kHz, -10 dB); QZZCWAT
- Playback gain adjustment (315 Hz, 0 dB); QZZCFM
- Recording/playback frequency response adjustment; QZZCFM (315 Hz/0 dB, 315 Hz/-20 dB, 12.5 kHz~63 Hz/-20 dB)  
 QZZCRA (Normal blank Tape)  
 QZZCRX (CrO<sub>2</sub> blank Tape)  
 QZZCRZ (Metal blank Tape)

**HEAD AZIMUTH ADJUSTMENT (DECK 1/2)**

1. Connect the measuring instrument as shown in Fig. 3.
2. Replace azimuth screws for both forward and reverse direction after removing the screw-locking bond left on the head base.  
Fine adjustment of azimuth can not be performed with remaining the bond on the head base.  
(Supply part No. of azimuth adjusting screw: RHD17015)
3. Playback the azimuth adjustment portion (8 kHz, -20 dB) of test tape (QZZCFM). Adjust the azimuth adjusting screw until the outputs of the L/R-ch are maximized. (Refer to Fig. 4.)  
Make sure that the difference in the peak level between the left and right channels does not exceed 0.5 dB.
4. Perform the same adjustment in reverse playback mode.

**Check of the level difference forward and reverse directions**

5. Playback the playback gain adjustment portion (315 Hz, 0 dB) of test tape (QZZCFM). Check if level difference between forward and reverse direction is within 1.5 dB.
6. After the adjustment, apply screwlock to the azimuth adjusting screw.

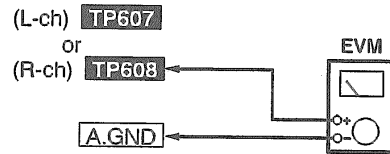

Fig. 3

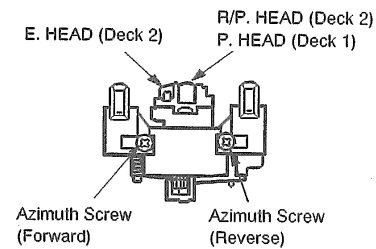

Fig. 4

**TAPE SPEED ADJUSTMENT (DECK 1/2)**

**Note:** When connecting the unit to other system components for testing, short the section between the test points TP609 and TP604 and turn on the entire system. (The unit is set to the TEST mode, and either the DECK1 or DECK2 indicators will blink.)

**Normal speed (Standard value: 3000 ± 45 Hz)**

1. Playback the middle portion of the test tape (QZZCWAT).
2. Adjust Deck 1 = VR801 and Deck 2 = VR803 for the output value shown below. (Refer to Fig. 2)

Adjustment target: 3000 ± 15 Hz (NORMAL speed)  
Standard value: 3000 ± 45 Hz (NORMAL speed)

**High speed [Set the unit to forward (FWD) mode.]**

3. Playback the middle portion on the test tape (QZZCWAT).
4. Press the one touch tape edit (High) button.  
This will set the high speed mode.
5. At that time, check if the output from DECK 1 is within the standard value.

Standard value: 5000 ± 600 Hz (HIGH speed)

6. Adjust VR802 so that the output frequency of DECK 2 is within ± 30 Hz for the value of the output frequency of DECK 1. (Refer to Fig. 2.)

**Note:** When connecting the unit to other system components, disconnect the short between the test points TP609 and TP604.

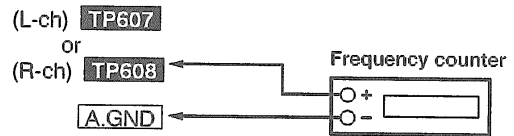

Fig. 5

**PLAYBACK GAIN ADJUSTMENT (DECK1/2)**

1. Find the start of the 315 Hz/0 dB section of the test tape (QZZCFM), insert the tape into Deck1 and 2, and play it back (FWD)
3. Adjust Deck 2 : VR102 (L-ch) [VR103 (R-ch)] and Deck 1 : VR104 (L-ch) [VR101 (R-ch)] so that the output is within the standard value. (Refer to Fig. 2.)

Standard value : 280 mV ± 15 mV

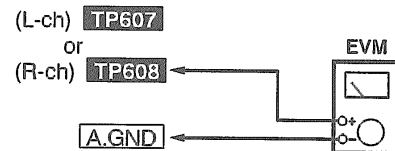

Fig. 6

**ERASE CURRENT CONFIRMATION (DECK2)**

1. Insert the blank tape into Deck2, and press the REC PAUSE button.
3. Check if the output at this time between the erase current confirmation point TP301 and TP302 (the output on both edged of R313) is within the standard value. (Refer to Fig. 7.)

Standard value	EVM reading
Normal tape : 85 ± 25 mA	(85 ± 25 mV)
CrO2 tape : 150 ± 25 mA	(150 ± 25 mV)
Metal tape : 185 ± 25 mA	(185 ± 25 mV)

**Note:** The test tape is not required when confirming the erase current.

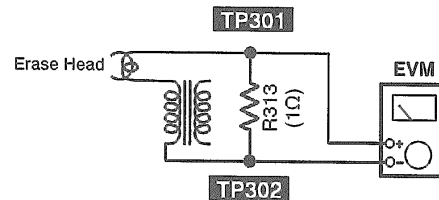

Fig. 7



**Playback frequency response check (DECK 1/2)**

Playback the 315 Hz/-20 dB and 12.5 kHz to 63 Hz/-20 dB sections of the test tape (QZZCFM) and then, using the 315 Hz/-20 dB playback output as a reference (0 dB), confirm that the playback frequency response is within the range shown in Fig. 9.

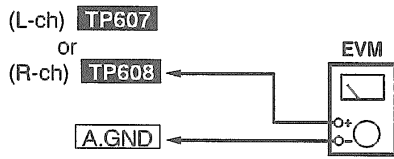

Fig. 8

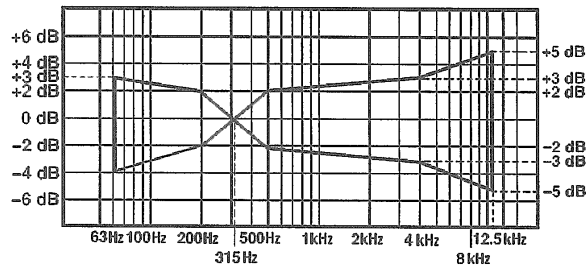

Fig. 9

**Recording/playback frequency response and gain check (DECK 2)**

**Normal tape check**

1. Insert a Normal-type blank tape (QZZCRA) into Deck 2.
2. Record signals at 50 Hz, 100 Hz, 200 Hz, 500 Hz, 1 kHz, 2 kHz, 10 kHz and 12.5 kHz (28 mV).
3. Set the playback frequency of the recorded signals at 1 kHz as the reference response (0 dB).
4. Playback the recorded signals to confirm that the output is within the range of the overall frequency response shown in Fig. 11.

**CrO<sub>2</sub>/Metal tape check**

5. Repeat steps 2 to 4 for each tape and confirm that the output for each is within the range of the overall frequency response shown in Fig. 12.

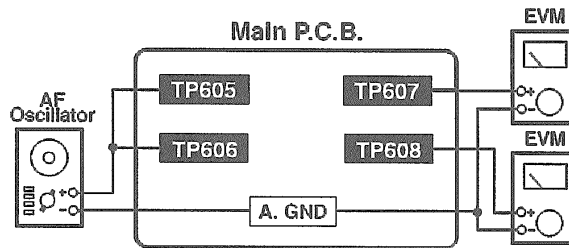

Fig. 10

**Normal Overall frequency response chart (NR OFF)**

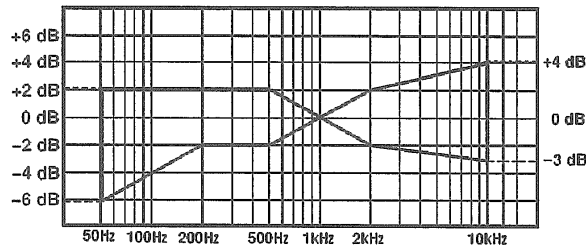

Fig. 11

**CrO<sub>2</sub> Metal Overall frequency response chart (NR OFF)**

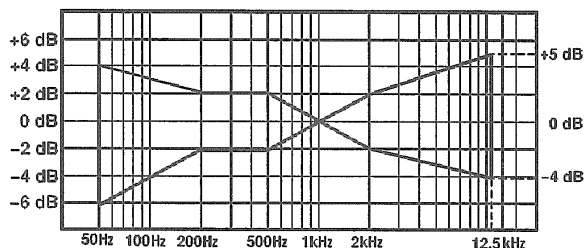

Fig. 12

## ■ Schematic Diagram

	Page
<b>A</b> MAIN CIRCUIT .....	19~22
<b>B</b> MECHANISM CIRCUIT (DECK 1) .....	21
<b>C</b> MECHANISM CIRCUIT (DECK 2) .....	21
<b>D</b> POWER SUPPLY CIRCUIT .....	22
<b>E</b> OPERATION CIRCUIT .....	23

• This schematic diagram may be modified at any time with the development of new technology.

### Notes:

- S900 : Stop switch (■)
- S901 : DECK 2 cassette holder open switch (▲ OPEN)
- S902 : One-touch tape edit switch (TAPE EDIT/HIGH)
- S903 : One-touch tape edit switch (TAPE EDIT/NOR)
- S904 : Record pause switch (● REC PAUSE)
- S905 : Dolby noise reduction switch (DOLBY NR)
- S906 : Fast forward/tape program sensor switch (▶▶▶)
- S907 : Forward side playback switch (▶)
- S909 : Reverse side playback switch (◀)
- S910 : Rewind/tape program sensor switch (◀◀◀)
- S911 : Reverse mode select switch (REV MODE)
- S912 : DECK 1/DECK 2 select switch (DECK 1/2)
- S913 : Counter display switch (COUNTER/DISPLAY)
- S914 : Counter reset switch (COUNTER/RESET)
- S915 : DECK 1 cassette holder open switch (▲ OPEN)
- S951 : DECK 1 mode detect switch
- S952 : DECK 1 half detect switch
- S953 : DECK 1 CrO<sub>2</sub> tape detect switch
- S971 : DECK 2 mode detect switch
- S972 : DECK 2 half detect switch
- S973 : DECK 2 CrO<sub>2</sub> tape detect switch
- S974 : DECK 2 reverse side record prevention tab detect switch
- S975 : DECK 2 forward side record prevention tab detect switch
- S976 : DECK 2 METAL tape detect switch
- VR101 : DECK 1 Playback gain adjustment (R-ch)
- VR102 : DECK 2 Playback gain adjustment (L-ch)
- VR103 : DECK 2 Playback gain adjustment (R-ch)
- VR104 : DECK 1 Playback gain adjustment (L-ch)
- VR801 : DECK 1 tape speed adjustment (normal)
- VR802 : DECK 2 tape speed adjustment (high)
- VR803 : DECK 2 tape speed adjustment (normal)

• Indicated voltage values are the standard values for the unit measured by the DC electronic circuit tester (high-impedance) with the chassis taken as standard. Therefore, there may exist some errors in the voltage values, depending on the internal impedance of the DC circuit tester.

No mark : Playback ( ) : Recording

### • Important safety notice:

Components identified by ▲ mark have special characteristics important for safety. Furthermore, special parts which have purposes of fire-retardant (resistors), high-quality sound (capacitors), low-noise (resistors), etc. are used. When replacing any of components, be sure to use only manufacturer's specified parts shown in the parts list.

### • Caution!

IC and LSI are sensitive to static electricity.  
Secondary trouble can be prevented by taking care during repair.  
Cover the parts boxes made of plastics with aluminum foil.  
Ground the soldering iron.  
Put a conductive mat on the work table.  
Do not touch the legs of IC or LSI with the fingers directly.

### • Voltage and signal line

→ : Positive voltage line    → : Playback signal Line    → : Recording signal Line



A MAIN CIRCUIT (P.C.Board: on page 24)

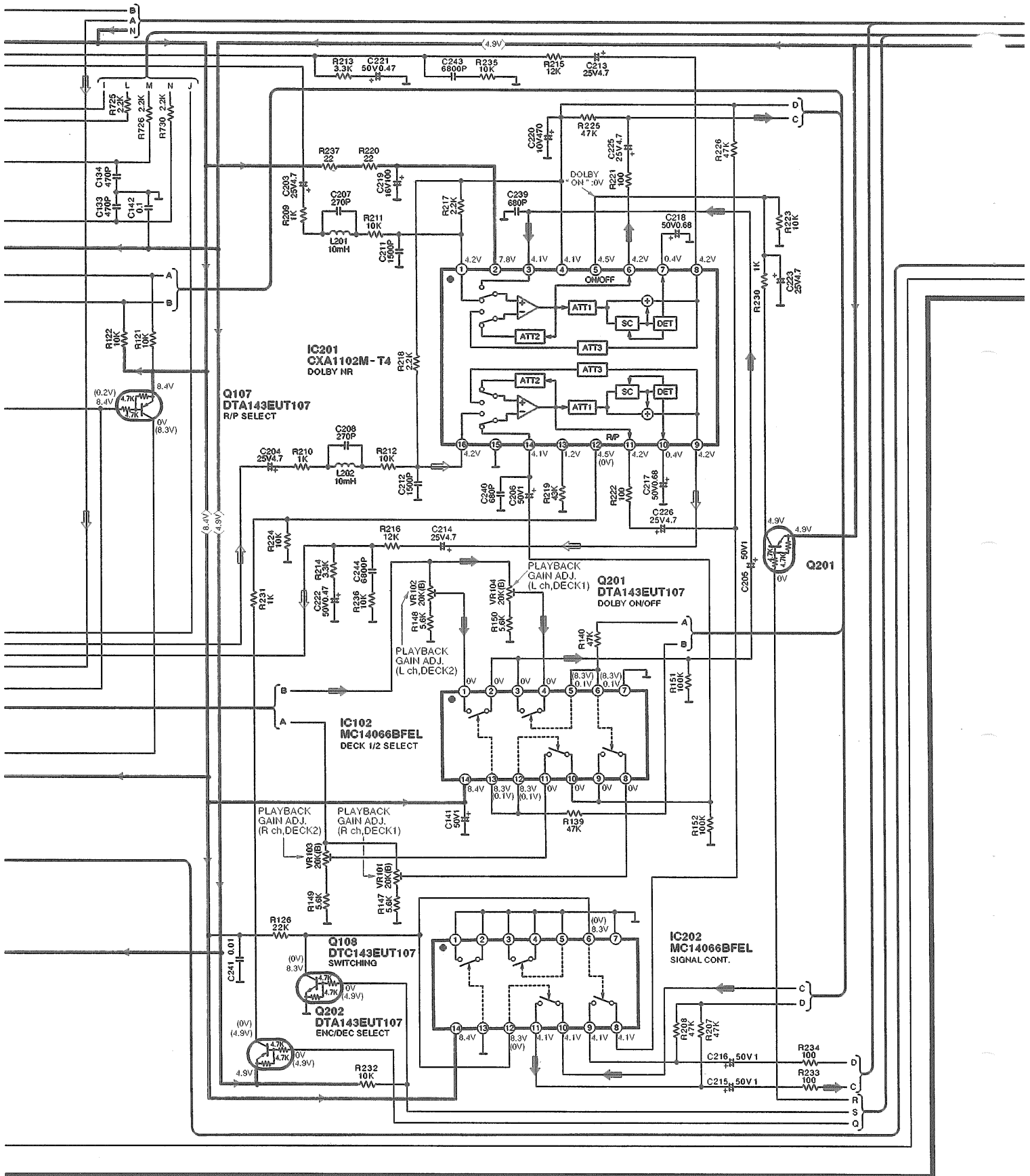

→ : Positive voltage line    → : Playback signal Line    → : Recording signal Line

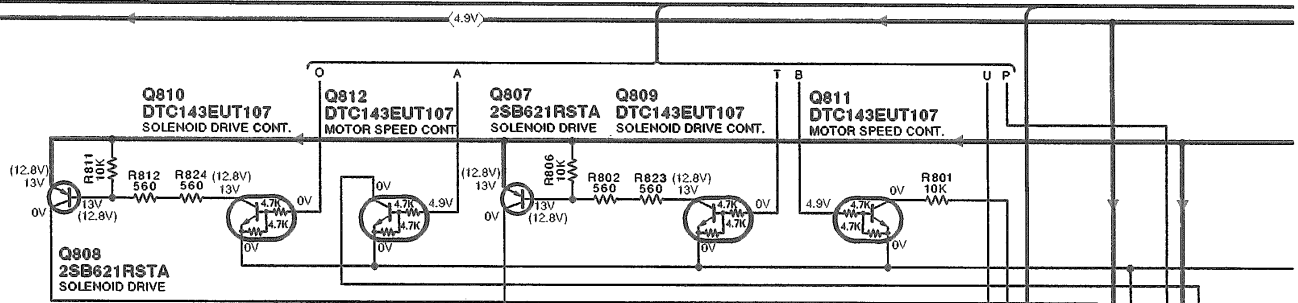

**B MECHANISM CIRCUIT (DECK1)**  
 (P.C.Board: on page 25)

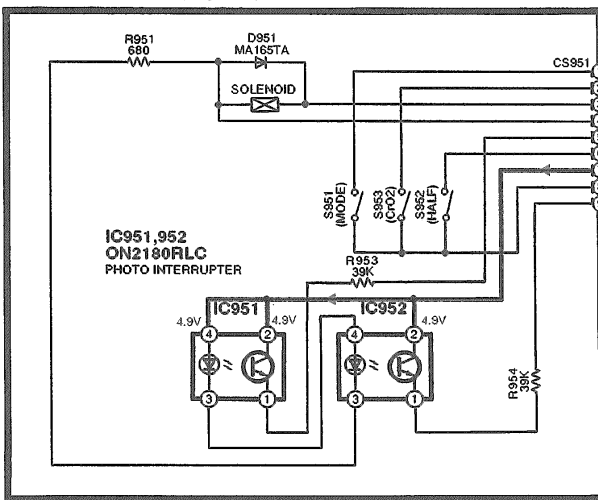

**C MECHANISM CIRCUIT (DECK2)**  
 (P.C.Board: on page 25)

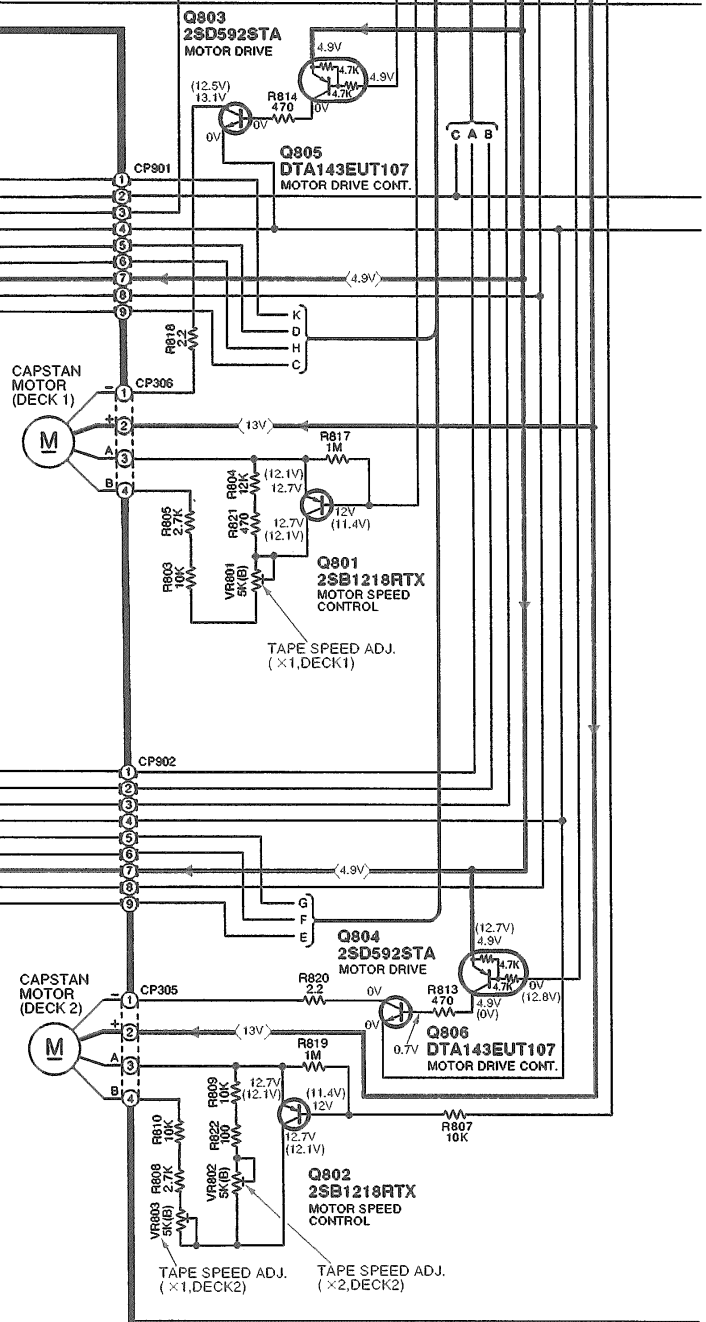
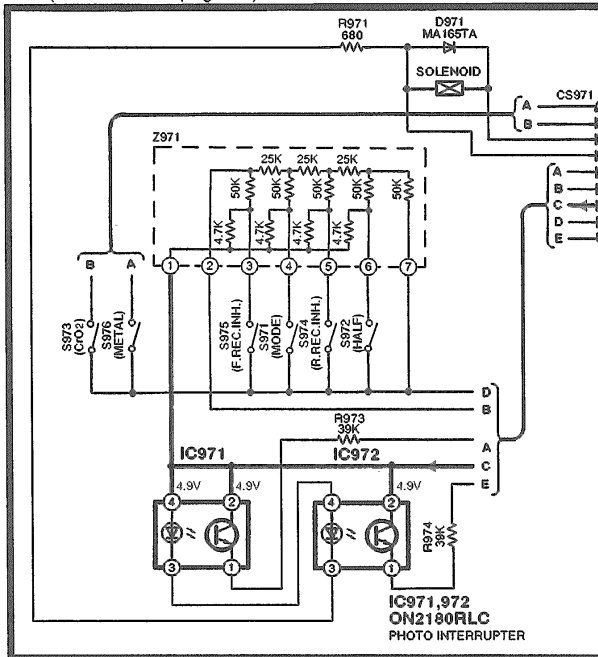



→ : Positive voltage line    → : Playback signal Line    ⇨ : Recording signal Line

**E** OPERATION CIRCUIT (P.C.Board: on page 25)

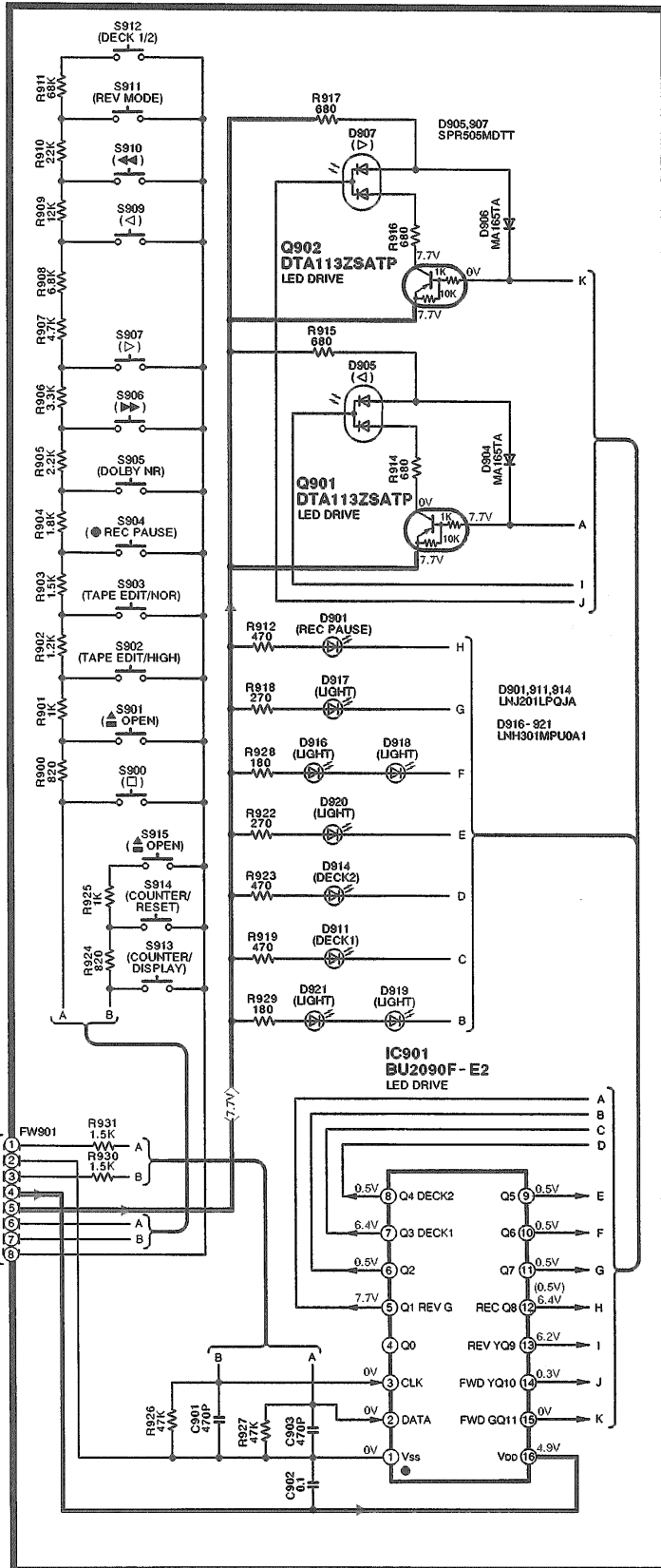

# Printed Circuit Board Diagram

• This circuit board diagram may be modified at any time with the development of new technology.

**A** MAIN P.C.B. (REP2306A-M)

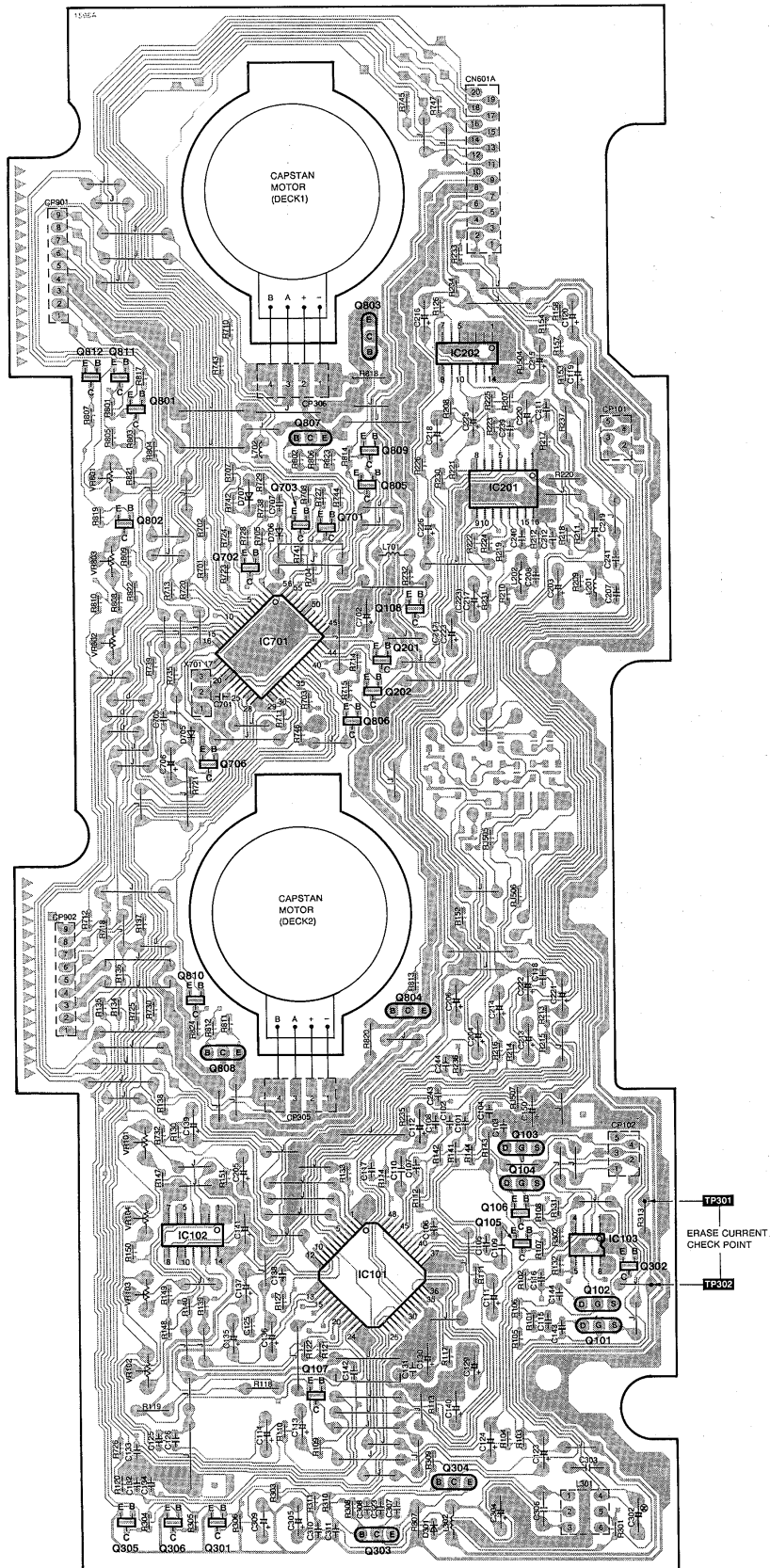



**B** MECHANISM P.C.B. (DECK1) (REP2132B)

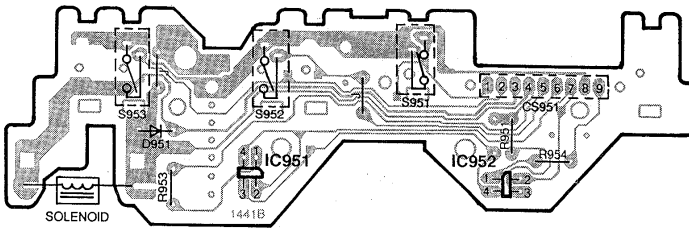

**C** MECHANISM P.C.B. (DECK2) (REP2131D)

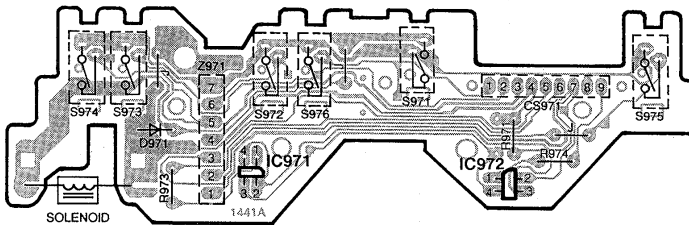

**D** POWER SUPPLY P.C.B. (REP2367A-P)

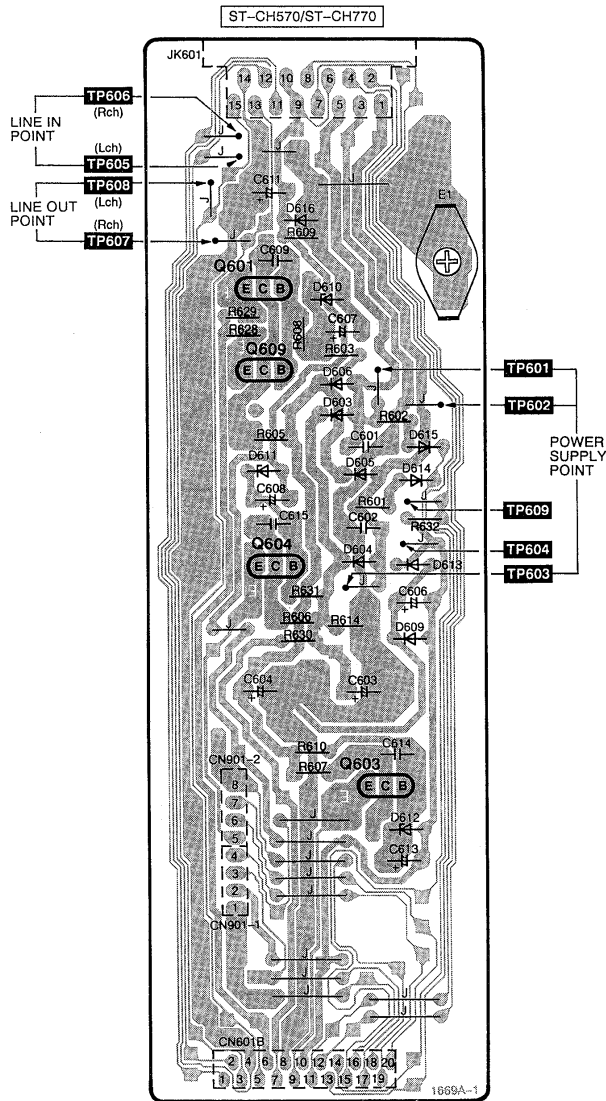

**E** OPERATION P.C.B. (REP2307A-S)

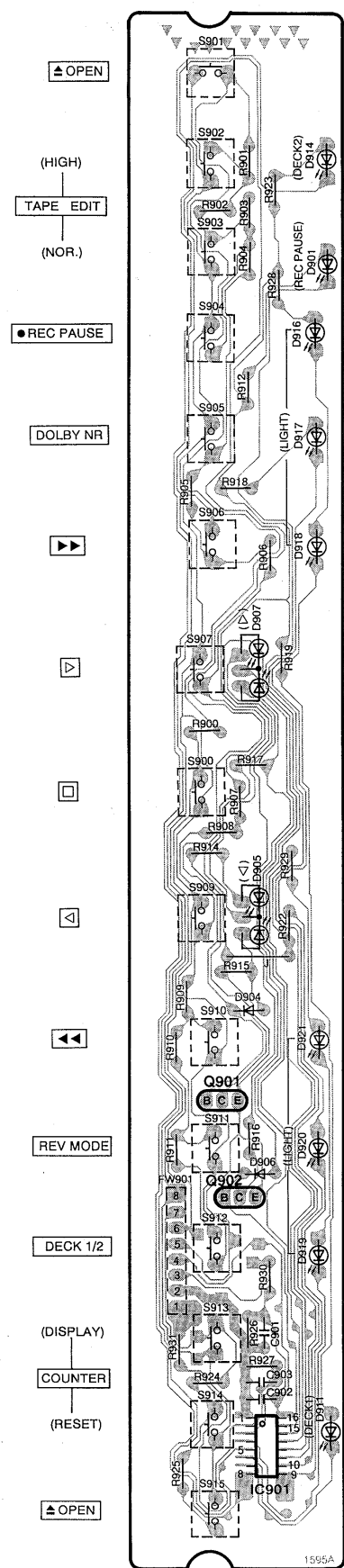

<p>MC14066BFEL 14PIN BU2090F-E2 16PIN CXA1102M-T4 16PIN</p>	<p>BA7755AF</p>	<p>CXA1998QT6</p>	<p>M37471M4650F</p>	<p>ON2180RLC</p>
<p>2SD1450RSTA DTA113ZSATP</p>	<p>2SD2137PQTA</p>	<p>2SD592NCR 2SB621RSTA</p>	<p>2SB1218RTX 2SD1819RTX 2SD2436STXRA DTA143EUT107 DTC114EUT107 DTC143EUT107</p>	<p>DTC144EUT107</p>
<p>2SJ164QTA 2SJ164RTA</p>	<p>MA110TX</p>	<p>RL1N4003N02</p>	<p>MA165 MA723TA</p>	<p>MTZJ5R1BTA MTZJ5R6BTA MTZJ8R2BTA MTZJ9R1BTA</p>
<p>SPR505MDTT</p>	<p>LNJ201LPQJA</p>	<p>LNH301MPU0A1</p>		

## ■ Wiring Connection Diagram

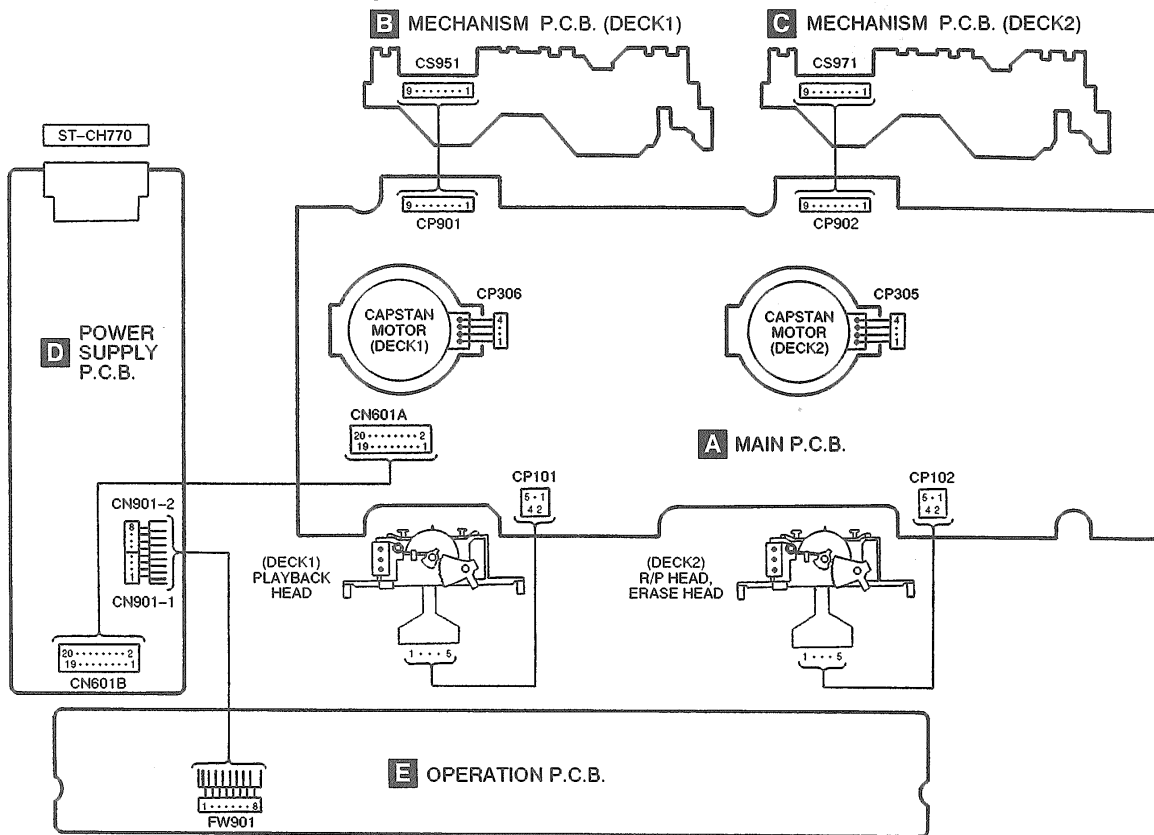

## ■ Function of IC Terminals

### ● IC701 (M37471M4650F)

Pin No.	Terminal Name	I/O	Function
1	N.C.	—	Not used
2	DATA IN	I	Serial data input
3	LED-DATA	O	Serial data signal output for LED drive IC
4	LED-CLK	O	Serial clock signal output for LED drive IC
5	SPEED2	O	DECK 2 motor speed control signal output
6	SPEED1	O	DECK 1 motor speed control signal output
7, 8	KEY1, 2	I	Operation switch signal input
9	PHOTO1-S	I	DECK 1 supply side reel pulse input
10	PHOTO1-T	I	DECK 1 take-up side reel pulse input
11	PHOTO2-S	I	DECK 2 supply side reel pulse input
12	AD-SW	I	DECK 2 mechanism switch signal input (Half, Mode, F. REC INH., R. REC INH.)
13	PHOTO2-T	I	DECK 2 take-up side reel pulse input
14	ATS2	I	DECK 2 mechanism switch signal input (NORMAL/CrO <sub>2</sub> /METAL)
15	VREF	—	Reference voltage input terminal for A/D converter (+5 V)
16, 17	N.C.	—	Not used
18	XIN	I	Clock signal input
19	XOUT	O	Clock signal output
20	N.C.	—	Not used
21	AVSS	—	Connect to GND
22	VSS	—	GND terminal
23	VCC	—	Power supply (+5 V)
24	N.C.	—	Not used
25	HALF1	I	DECK 1 mechanism switch signal input (Half)
26	CRO2-1	I	DECK 1 mechanism switch signal input (NORMAL/CrO <sub>2</sub> )
27	N.C.	—	Not used
28	RESET	I	Reset signal input

Pin No.	Terminal Name	I/O	Function
29	N.C.	I	Not used
30	HALT	I	AC power source detect signal input
31	TPS	I	TPS signal input
32	TEST	I	Test mode select signal input
33	MODE	I	DECK 1 mechanism switch signal input (Mode)
34	N.C.	—	Not used
35	A-DATA	O	Serial data signal output for audio IC
36	A-CLK	O	Serial clock signal output for audio IC
37	A-LATCH	O	Serial latch signal output for audio IC
38	PL2	O	DECK 2 solenoid drive signal output
39	MOTOR2	O	DECK 2 motor drive signal output
40, 41	MIC2, 1	O	Not used
42	ENC/DEC	O	DOLBY NR record/play mode select signal output
43	DOLBY ON/OFF	O	DOLBY NR ON/OFF control signal output
44, 45	N.C.	—	Not used
46	LMT	O	Muting control signal output
47	PL1	O	DECK 1 solenoid drive signal output
48	MOTOR1	O	DECK 1 motor drive signal output
49	—	—	Not used
50	N.C.	—	Not used
51	VSS	—	GND terminal
52	REQ	I	Serial communication request signal input
53	CS	O	Serial communication complete signal output
54	CLK	O	Serial communication clock signal output
55	DATA OUT	O	Serial communication data signal output
56	N.C.	—	Not used

# Block Diagram

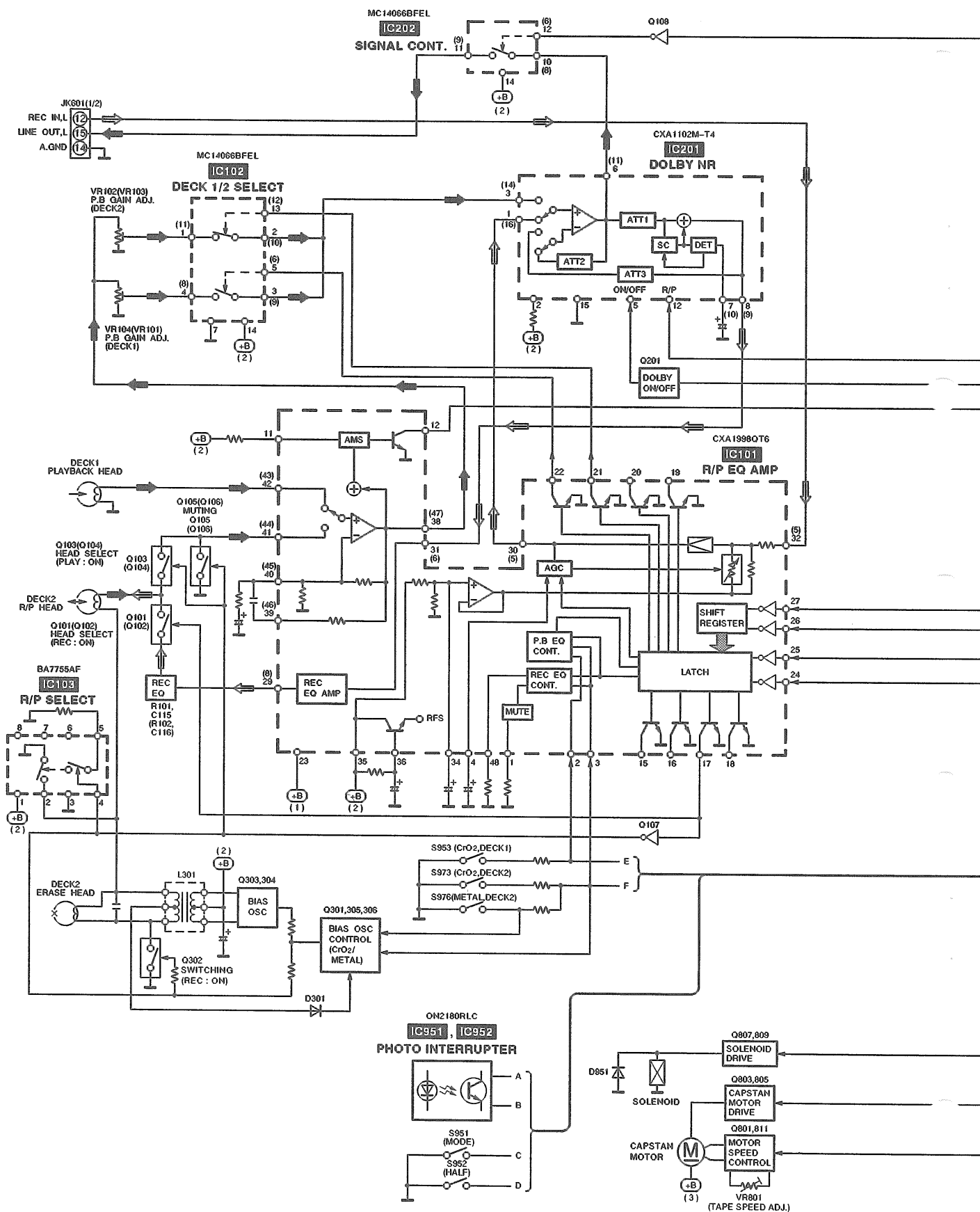

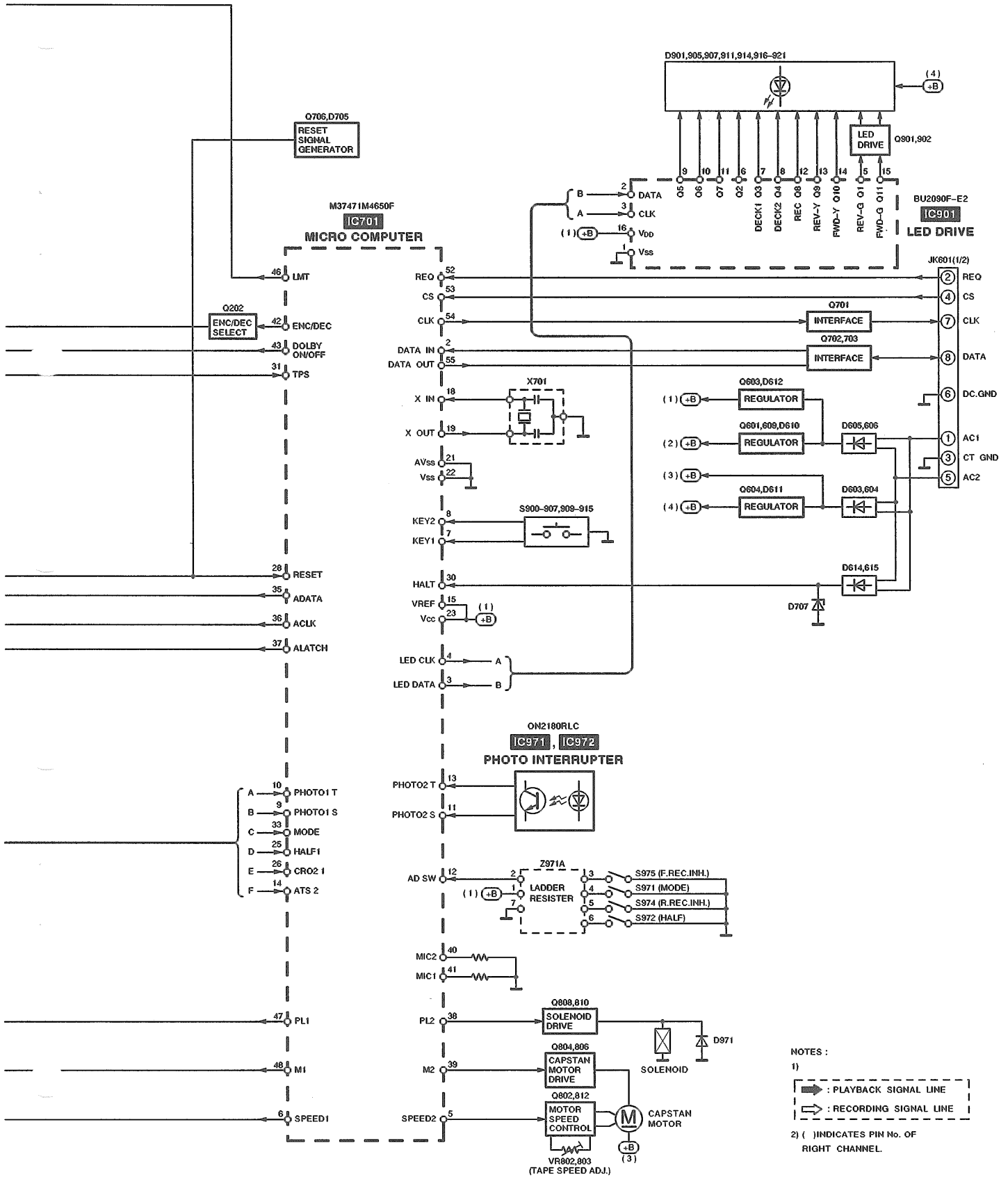

NOTES :

1) : PLAYBACK SIGNAL LINE  
 : RECORDING SIGNAL LINE

2) ( ) INDICATES PIN No. OF RIGHT CHANNEL.

## ■ Replacement Parts List

**Notes:** \*Important safety notice:

 Components identified by  $\Delta$  mark have special characteristics important for safety.

Furthermore, special parts which have purposes of fire-retardant (resistors), high-quality sound (capacitors), low-noise (resistors), etc. are used.

When replacing any of components, be sure to use only manufacturer's specified parts shown in the parts list.

\*The parenthesized indications in the Remarks columns specify the areas. (Refer to the cover page for area.)

Parts without these indications can be used for all areas.

\*[M] Indicates in Remarks columns parts that are supplied by MESA.

Ref. No.	Part No.	Part Name & Description	Remarks	Ref. No.	Part No.	Part Name & Description	Remarks
		INTEGRATED CIRCUIT(S)		D614, D615	MA165	DIODE	$\Delta$
				D616	MA165	DIODE	
				D705, 706	MA110TX	DIODE	
IC101	CKA1998QT6	IC, R/P EQ AMP.		D707	MTZJ5R1BTA	DIODE	$\Delta$
IC102	MC14066BFEL	IC, DECK 1/2 SELECT		D901	LNJ201LPQJA	L. E. D.	
IC103	BA7755AF	IC, REC./PLAY SELECT		D904	MA165	DIODE	
IC201	CKA1102M-T4	IC, DOLBY NR		D905	SPR505MDTT	L. E. D.	
IC202	MC14066BFEL	IC, SIGNAL CONT		D906	MA165	DIODE	
IC701	M37471M4650F	IC, MICRO COMPUTER		D907	SPR505MDTT	L. E. D.	
IC901	BU2090F-E2	IC, LED DRIVE	[M]	D911	LNJ201LPQJA	L. E. D.	
IC951, 952	ON2180RLC	IC, PHOTO INTERRUPTER		D914	LNJ201LPQJA	L. E. D.	
IC971, 972	ON2180RLC	IC, PHOTO INTERRUPTER		D916-921	LNH301MPU0A1	L. E. D.	
		TRANSISTOR(S)		D951	MA165	DIODE	
				D971	MA165	DIODE	
						VARIABLE RESISTOR(S)	
Q101, 102	2SJ164RTA	TRANSISTOR		VR101	EVNDCAA03B24	DECK 1 PLAYBACK GAIN(R-ch)	
Q103, 104	2SJ164QTA	TRANSISTOR		VR102	EVNDCAA03B24	DECK 2 PLAYBACK GAIN(L-ch)	
Q105, 106	2SD1819RTX	TRANSISTOR		VR103	EVNDCAA03B24	DECK 2 PLAYBACK GAIN(R-ch)	
Q107	DTA143EUT107	TRANSISTOR		VR104	EVNDCAA03B24	DECK 1 PLAYBACK GAIN(L-ch)	
Q108	DTC143EUT107	TRANSISTOR		VR801	EVNDCAA03B53	DECK 1 TAPE SPEED(NORMAL)	
Q201, 202	DTA143EUT107	TRANSISTOR		VR802	EVNDCAA03B53	DECK 2 TAPE SPEED(HIGT)	
Q301	2SD1819RTX	TRANSISTOR		VR803	EVNDCAA03B53	DECK 2 TAPE SPEED(NORMAL)	
Q302	2SD2436STXRA	TRANSISTOR				COIL(S)	
Q303, 304	2SD1450RSTA	TRANSISTOR		L201, 202	ELELN103KA	COIL	
Q305, 306	DTC144EUT107	TRANSISTOR		L301	RL08B006-K	COIL	
Q601	2SD2137PQTA	TRANSISTOR	$\Delta$	L302	RLQB101KT-D	COIL	
Q603, 604	2SD2137PQTA	TRANSISTOR	$\Delta$	L701	RLQA100JT-Y	COIL	
Q609	2SD2137PQTA	TRANSISTOR	$\Delta$	L702	ELJPC330KF	COIL	
Q701-703	2SD1819RTX	TRANSISTOR				OSCILLATOR(S)	
Q706	DTC114EUT107	TRANSISTOR		X701	EFOEC8004T4	OSCILLATOR(8 MHz)	
Q801, 802	2SB1218RTX	TRANSISTOR				SWITCH(ES)	
Q803, 804	2SD592NCR	TRANSISTOR		S900	EVQ21405R	SW, STOP	
Q805, 806	DTA143EUT107	TRANSISTOR		S901	EVQ21405R	SW, DECK 2 OPEN	
Q807, 808	2SB621RSTA	TRANSISTOR		S902	EVQ21405R	SW, TAPE EDIT/HIGT	
Q809-812	DTC143EUT107	TRANSISTOR		S903	EVQ21405R	SW, TAPE EDIT/NOR	
Q901, 902	DTA113ZSATP	TRANSISTOR		S904	EVQ21405R	SW, REC PAUSE	
		DIODE(S)		S905	EVQ21405R	SW, DOLBY NR	
				S906	EVQ21405R	SW, FF TPS	
D301	MA110TX	DIODE					
D603-606	RL1N4003N02	DIODE	$\Delta$				
D609	MA723TA	DIODE					
D610	MTZJ9R1BTA	DIODE	$\Delta$				
D611	MTZJ8R2BTA	DIODE	$\Delta$ [M]				
D612	MTZJ5R6BTA	DIODE	$\Delta$				
D613	MA723TA	DIODE					

Ref. No.	Part No.	Part Name & Description	Remarks				
S907	EVQ21405R	SW, FWD PLAY					
S909	EVQ21405R	SW, REV PLAY					
S910	EVQ21405R	SW, REW TPS					
S911	EVQ21405R	SW, REV MODE SELECT					
S912	EVQ21405R	SW, DECK 1/2 SELECT					
S913	EVQ21405R	SW, COUNTER DISPLAY					
S914	EVQ21405R	SW, COUNTER/RESET					
S915	EVQ21405R	SW, DECK 1 OPEN					
S951	RSH1A018-1U	SW, DECK 1 MODE					
S952	RSH1A019-2U	SW, DECK 1 HALF					
S953	RSH1A019-2U	SW, DECK 1 ATS/CrO2					
S971	RSH1A018-1U	SW, DECK 2 MODE					
S972	RSH1A019-2U	SW, DECK 2 HALF					
S973	RSH1A019-2U	SW, DECK 2 ATS/CrO2					
S974	RSH1A019-2U	SW, DECK 2 R. REC. INH.					
S975	RSH1A019-2U	SW, DECK 2 F. REC. INH.					
S976	RSH1A019-2U	SW, DECK 2 ATS/METAL					
		JACK (S)					
JK601	RJT065K15	SYSTEM CONNECTOR (15P)					
		CONNECTOR (S)					
CN901-1, 2	RJS1A6604	CONNECTOR (4P)					
CN601A	RJT077K20	CONNECTOR (20P)	[M]				
CN601B	RJU077K20	CONNECTOR (20P)	[M]				
CP101, 102	RJS1A6805	CONNECTOR (5P)					
CP305, 306	RJR0113	CONNECTOR (MOTOR) (4P)					
CP901, 902	RJT071HD9A	CONNECTOR (9P)					
CS951	RJU071HD9M	CONNECTOR (9P)					
CS971	RJU071HD9M	CONNECTOR (9P)					
		COMPONENT COMBINATION					
Z971	EXBF7L355SYV	COMPONENT COMBINATION					
		GND PLATE					
E1	SNE1004-2	GND PLATE					

Notes : \* Capacity values are in microfarads ( $\mu\text{F}$ ) unless specified otherwise, P=Pico-farads (pF) F=Farads (F)  
 \* Resistance values are in ohms, unless specified otherwise, 1K=1,000(OHM) , 1M=1,000k(OHM)

Ref. No.	Part No.	Values & Remarks	Ref. No.	Part No.	Values & Remarks	Ref. No.	Part No.	Values & Remarks
		RESISTORS	R233, 234	ERJ6GEYJ101V	1/10W 100	R745	ERJ6GEYJ101V	1/10W 100
			R235, 236	ERJ6GEYJ103V	1/10W 10K	R746	ERJ6GEYJ103V	1/10W 10K
			R237	ERDS2TJ220T	1/4W 22	R747	ERJ6GEYJ102V	1/10W 1K
R101, 102	ERJ6GEYJ562V	1/10W 5.6K	R301	ERJ6GEYJ103V	1/10W 10K	R801	ERJ6GEYJ103V	1/10W 10K
R103, 104	ERJ6GEYJ104V	1/10W 100K	R302	ERJ6GEYJ182V	1/10W 1.8K	R802	ERJ6GEYJ561V	1/10W 560
R105, 106	ERJ6GEYJ334V	1/10W 330K	R303	ERJ6GEYJ222V	1/10W 2.2K	R803	ERJ6GEYJ103V	1/10W 10K
R107, 108	ERJ6GEYJ103V	1/10W 10K	R304	ERJ6GEYJ153V	1/10W 15K	R804	ERJ6GEYJ123V	1/10W 12K
R109, 110	ERJ6GEYJ102V	1/10W 1K	R305	ERJ6GEYJ183V	1/10W 18K	R805	ERJ6GEYJ272V	1/10W 2.7K
R111	ERJ6GEYJ820V	1/10W 82	R306	ERJ6GEYJ333V	1/10W 33K	R806, 807	ERJ6GEYJ103V	1/10W 10K
R112	ERJ6GEYJ820V	1/8W 82	R307 $\Delta$	ERDS1FVJ2R2T	1/2W 2.2	R808	ERJ6GEYJ272V	1/10W 2.7K
R113	ERJ6GEYJ123V	1/10W 12K	R308	ERJ6GEYJ102V	1/10W 1K	R809-811	ERJ6GEYJ103V	1/10W 10K
R114	ERJ6GEYJ273V	1/10W 27K	R309-311	ERJ6GEYJ472V	1/10W 4.7K	R812	ERJ6GEYJ561V	1/10W 560
R117	ERJ6GEYJ102V	1/10W 1K	R313	ERDS2TJ1R0	1/4W 1.0	R813, 814	ERJ6GEYJ471V	1/10W 470
R118, 119	ERDS2TJ220T	1/4W 22	R601, 602	ERDS2TJ472	1/4W 4.7K	R817	ERJ6GEYJ105	1/10W 1M
R120	ERJ6GEYJ104V	1/10W 100K	R603	ERDS2TJ221	1/4W 220	R818	ERDS2TJ2R2T	1/4W 2.2
R121, 122	ERJ6GEYJ103V	1/10W 10K	R605 $\Delta$	ERD2FCVJ4R7T	1/4W 4.7	R819	ERJ6GEYJ105	1/10W 1M
R125	ERJ6GEYJ104V	1/10W 100K	R606, 607 $\Delta$	ERD2FCVG100T	1/4W 10	R820	ERDS2TJ2R2T	1/4W 2.2
R126	ERJ6GEYJ223V	1/10W 22K	R608, 609	ERDS2TJ101	1/4W 100	R821	ERJ6GEYJ471V	1/10W 470
R127	ERJ6GEYJ472V	1/10W 4.7K	R610	ERDS2TJ152	1/4W 1.5K	R822	ERJ6GEYJ101V	1/10W 100
R130	ERJ6GEYJ475V	1/10W 4.7M	R614	ERDS2TJ222	1/4W 2.2K	R823, 824	ERJ6GEYJ561V	1/10W 560
R131	ERJ6GEYJ334V	1/10W 330K	R628, 629	ERDS2TJ1R0	1/4W 1.0	R900	ERDS2TJ821	1/4W 820
R132	ERJ6GEYJ273V	1/10W 27K	R630	ERDS2TJR47T	1/4W 0.47	R901	ERDS2TJ102	1/4W 1K
R133	ERJ6GEYJ333V	1/10W 33K	R631	ERDS2TJ561	1/4W 560	R902	ERDS2TJ122	1/4W 1.2K
R134	ERJ6GEYJ392V	1/10W 3.9K	R632	ERDS2TJ473	1/4W 47K	R903	ERDS2TJ152	1/4W 1.5K
R135	ERJ6GEYJ682V	1/10W 6.8K	R701, 702	ERJ6GEYJ103V	1/10W 10K	R904	ERDS2TJ182	1/4W 1.8K
R136, 137	ERJ6GEYJ222V	1/10W 2.2K	R703	ERJ6GEYJ562V	1/10W 5.6K	R905	ERDS2TJ222	1/4W 2.2K
R138	ERJ6GEYJ472V	1/10W 4.7K	R704	ERJ6GEYJ472V	1/10W 4.7K	R906	ERDS2TJ332	1/4W 3.3K
R139, 140	ERJ6GEYJ473V	1/10W 47K	R705	ERJ6GEYJ473V	1/10W 47K	R907	ERDS2TJ472	1/4W 4.7K
R141	ERJ6GEYJ101V	1/8W 100	R707, 708	ERJ6GEYJ472V	1/10W 4.7K	R908	ERDS2TJ682T	1/4W 6.8K
R142	ERJ6GEYJ101V	1/10W 100	R710	ERJ6GEYJ102V	1/10W 1K	R909	ERDS2TJ123	1/4W 12K
R143	ERDS2TJ101	1/4W 100	R711	ERJ6GEYJ104V	1/10W 100K	R910	ERDS2TJ223	1/4W 22K
R144	ERJ6GEYJ101V	1/10W 100	R712, 713	ERJ6GEYJ683V	1/10W 68K	R911	ERDS2TJ683	1/4W 68K
R147-150	ERJ6GEYJ562V	1/10W 5.6K	R714, 715	ERJ6GEYJ473V	1/10W 47K	R912	ERDS2TJ471	1/4W 470
R151, 152	ERJ6GEYJ104V	1/10W 100K	R718	ERJ6GEYJ683V	1/8W 68K	R914-917	ERDS2TJ681	1/4W 680
R153, 154	ERJ6GEYJ681V	1/10W 680	R720	ERJ6GEYJ683V	1/10W 68K	R918	ERDS2TJ271	1/4W 270
R157, 158	ERJ6GEYJ223V	1/10W 22K	R721	ERJ6GEYJ472V	1/10W 4.7K	R919	ERDS2TJ471	1/4W 470
R207, 208	ERJ6GEYJ473V	1/10W 47K	R723, 724	ERJ6GEYJ102V	1/10W 1K	R922	ERDS2TJ271	1/4W 270
R209, 210	ERJ6GEYJ102V	1/10W 1K	R725, 726	ERJ6GEYJ222V	1/10W 2.2K	R923	ERDS2TJ471	1/4W 470
R211, 212	ERJ6GEYJ103V	1/10W 10K	R727	ERJ6GEYJ472V	1/10W 4.7K	R924	ERDS2TJ821	1/4W 820
R213, 214	ERJ6GEYJ332V	1/10W 3.3K	R728	ERJ6GEYJ332V	1/10W 3.3K	R925	ERDS2TJ102	1/4W 1K
R215, 216	ERJ6GEYJ123V	1/10W 12K	R729	ERJ6GEYJ472V	1/10W 4.7K	R926, 927	ERDS2TJ473	1/4W 47K
R217, 218	ERJ6GEYJ222V	1/10W 2.2K	R730	ERJ6GEYJ222V	1/10W 2.2K	R928, 929	ERDS2TJ181T	1/4W 180
R219	ERJ6GEYJ433V	1/10W 43K	R732	ERJ6GEYJ104V	1/10W 100K	R930, 931	ERDS2TJ152	1/4W 1.5K
R220	ERDS2TJ220T	1/4W 22	R735	ERJ6GEYJ472V	1/10W 4.7K	R951	ERDS2TJ681T	1/4W 680
R221, 222	ERJ6GEYJ101V	1/10W 100	R738	ERJ6GEYJ102V	1/10W 1K	R953, 954	ERDS2TJ393T	1/4W 39K
R223, 224	ERJ6GEYJ103V	1/10W 10K	R739	ERJ6GEYJ272V	1/10W 2.7K	R971	ERDS2TJ681T	1/4W 680
R225, 226	ERJ6GEYJ473V	1/10W 47K	R741	ERJ6GEYJ123V	1/10W 12K	R973, 974	ERDS2TJ393T	1/4W 39K
R230, 231	ERJ6GEYJ102V	1/10W 1K	R742	ERJ6GEYJ103V	1/10W 10K			
R232	ERJ6GEYJ103V	1/10W 10K	R743, 744	ERJ6GEYJ102V	1/10W 1K			CHIP JUMPER(S)



Ref. No.	Part No.	Values & Remarks	Ref. No.	Part No.	Values & Remarks			
J504-506	ERJ6GEY0R00V	1/10W 0	C310, 311	ECUV1H103KBN	50V 0.01U			
J507	ERJ8GEY0R00V	1/8W 0	C323	ECUV1H102KBN	50V 1000P			
		CAPACITORS	C601, 602	ECFR1H104ZF	50V 0.1U			
			C603, 604	ECA1CM222B	16V 2200U			
			C606	ECA1EM101B	25V 100U			
			C607	ECA1AM471B	10V 470U			
C101, 102	ECUV1H681KBN	50V 680P	C608	ECEA1AKA101B	10V 100U			
C103, 104	ECUV1H821KBN	50V 820P	C609	ECBT1E103ZF	25V 0.01U			
C105-108	ECUV1H330JCN	50V 33P	C611	ECEA1HKA010B	50V 1U			
C109, 110	ECQB1H183JF3	50V 0.018U	C613	ECEA1AKA470B	10V 47U			
C111, 112	ECEAOJKA470B	6.3V 47U	C614, 615	ECBT1E103ZF	25V 0.01U			
C113, 114	ECEA1EKA4R7B	25V 4.7U	C701	ECUV1H103KBN	50V 0.01U			
C115, 116	ECUV1H471KBN	50V 470P	C702	ECEAOJKA101B	6.3V 100U			
C117, 118	ECUV1H331KBN	50V 330P	C705	ECUV1E103ZFN	25V 0.01U			
C119, 120	ECEA1HKA010B	50V 1U	C706	RCE1HKA3R3BG	50V 3.3U			
C123, 124	ECEA1EKA4R7B	25V 4.7U	C707	ECUV1E103ZFN	25V 0.01U			
C125, 126	ECUV1H332KBN	50V 3300P	C901	ECBT1H471KB5	50V 470P			
C129	ECEA1AKA220B	10V 22U	C902	ECBT1H104ZF5	50V 0.1U			
C130	RCE1AKA101BG	10V 100U	C903	ECBT1H471KB5	50V 470P			
C131-134	ECUV1H471KBN	50V 470P						
C135, 136	ECEA1HKA010B	50V 1U						
C137	ECEA1HKA0R1B	50V 0.1U						
C138	ECUV1E473KBN	25V 0.047U						
C139	ECEAOJKA470B	6.3V 47U						
C140	RCE1CKA100BG	16V 10U						
C141	ECEA1HKA010B	50V 1U						
C142	ECUV1E104ZFN	25V 0.1U						
C143, 144	ECUV1H471KBN	50V 470P						
C150	RCE1AKA101BG	10V 100U						
C203, 204	ECEA1EKA4R7B	25V 4.7U						
C205, 206	ECEA1HKA010B	50V 1U						
C207, 208	ECUV1H271KBN	50V 270P						
C211, 212	ECUV1H152KBN	50V 1500P						
C213, 214	ECEA1EKA4R7B	25V 4.7U						
C215, 216	ECEA1HKA010B	50V 1U						
C217, 218	ECEA1HKAR68B	50V 0.68U						
C219	ECEA1CKA101B	16V 100U						
C220	RCE1ARC471BG	10V 470U						
C221, 222	RCE1HKAR47BG	50V 0.47U						
C223	ECEA1EKA4R7B	25V 4.7U						
C225, 226	ECEA1EKA4R7B	25V 4.7U						
C239, 240	ECUV1H681KBN	50V 680P						
C241	ECUV1H103KBN	50V 0.01U						
C243, 244	ECUV1H682KBN	50V 6800P						
C302	ECEA2AN2R2SB	100V 2.2U						
C303	ECQP2E682JZT	250V 6800P						
C304	RCE1AKA101BG	10V 100U						
C305	ECEA1HKA0R1B	50V 0.1U						
C306	ECQB1H393JF3	50V 0.039U						
C307	ECUV1H102KBN	50V 1000P						
C308	ECUV1H332KBN	50V 3300P						
C309	ECEAOJKA470B	6.3V 47U						

Note: The reference number SA represent the grease and tool used for this unit.

Ref. No.	Part No.	Part Name & Description	Remarks	Ref. No.	Part No.	Part Name & Description	Remarks
		CABINET PARTS		117	RML0371	LEVER	
				118	RML0372	LEVER	
				119	RML0374	LEVER	
1	RKMD290-K	TOP CABINET		120	RMMD131	ROD	
2	RHD30007-K1	SCREW		121	RMMD133	ROD	
3	XTBS3+8JFZ1	SCREW		122	RMQ0519	REEL CAP	
4	RKSO236-K	BOTTOM FRAME		123	RMS0398-1	SHAFT	
5	RFKGSCH770EK	FRONT PANEL ASS' Y		124	RSJ0003	PLUNGER ASS' Y	
6	RKA0068-N	FOOT		125	RUS609ZC	SPRING	
7	RMA0969	GND PLATE		126	RXF0049	FLYWHEEL ASS' Y	
8	RMRO909-X	HOLDER		127	RXF0050	FLYWHEEL ASS' Y	
9	RSC0453	SHIELD PLATE		128	RXG0040	GEAR	
10	RSC0454	SHIELD PLATE		129	RMMD283	SUB CHASSIS	
11	RDG0129-1	GEAR	DM	130	RXL0124	PINCH ROLLER ASS' Y	
12	SHG1654	RUBBER		130-1	RMBO401	SPRING	
13	REZO886	FLAT CABLE (8P) (FW901)		131	RXL0125	PINCH ROLLER ASS' Y	
14	RFKNSCH770AE	BUTTON ASS' Y		131-1	RMBO402	SPRING	
15	RFKLACH430GA	CASSETTE HOLDER (L) ASS' Y		132	RXL0126	ARM GEAR	
15-1	RUS757ZA	SPRING		133	RXQ0412	CHASSIS ASS' Y	
16	RFKLACH430GB	CASSETTE HOLDER (R) ASS' Y		133-1	RMBO405	SPRING	
16-1	RUS757ZA	SPRING		133-2	RMMD132	ROD	
17	RMBO474	SPRING		134	REMO055	MOTOR ASS' Y	
18	RMQ0577-1	FRAME		135	RHD26022	SCREW	
19	RYFO412-K	CASSETTE LID (L)		136	XTW2+5L	SCREW	
19-1	RGL0340-Q	PANEL LIGHT		137	XTW26+10S	SCREW	
19-2	RKWO461-Q	PANEL		138	XYC2+JF17	SCREW	
20	RYFO413-K	CASSETTE LID (R)		140	RFKJSCH770EK	MAIN CHASSIS ASS' Y	
20-1	RGL0340A-Q	PANEL LIGHT				GREASE OR JIG/TOOL	
20-2	RKWO462-Q	PANEL		SA1	QZZCFM	TEST TAPE (AZIMUTH/FREQ etc)	
21	XTBS26+10J	SCREW		SA2	QZZCWAT	TEST TAPE (TAPE SPEED etc)	
22	XTBS26+8J	SCREW		SA3	QZZCRA	BLANK TAPE (NORMAL POSITION)	
23	XTB3+10JFZ	SCREW		SA4	QZZCRX	BLANK TAPE (CrO2 POSITION)	
24	RMR1008-Q	LED HOLDER		SA5	QZZCRZ	BLANK TAPE (METAL POSITION)	
		MECHANISM PARTS		SA6	RZZOL01	SCREW LOCKING BOND	
101	RED0037	HEAD BLOCK (R/P)					
101-1	RHD17015	SCREW					
102	RED0038	HEAD BLOCK (P. B)					
102-1	RHD17015	SCREW					
103	RDG0300	REEL TABLE ASS' Y					
104	RDG0301	GEAR					
105	RDKO026	GEAR					
107	RDV0033-1	BELT1					
108	RDV0034	BELT2					
110	RLW147ZA	SPRING					
111	RMBO400	SPRING					
112	RMBO403	SPRING					
113	RMBO404	SPRING					
114	RMBO406	SPRING					
115	RMBO408	SPRING					
116	RML0370	LEVER					

■ Cabinet Parts Location

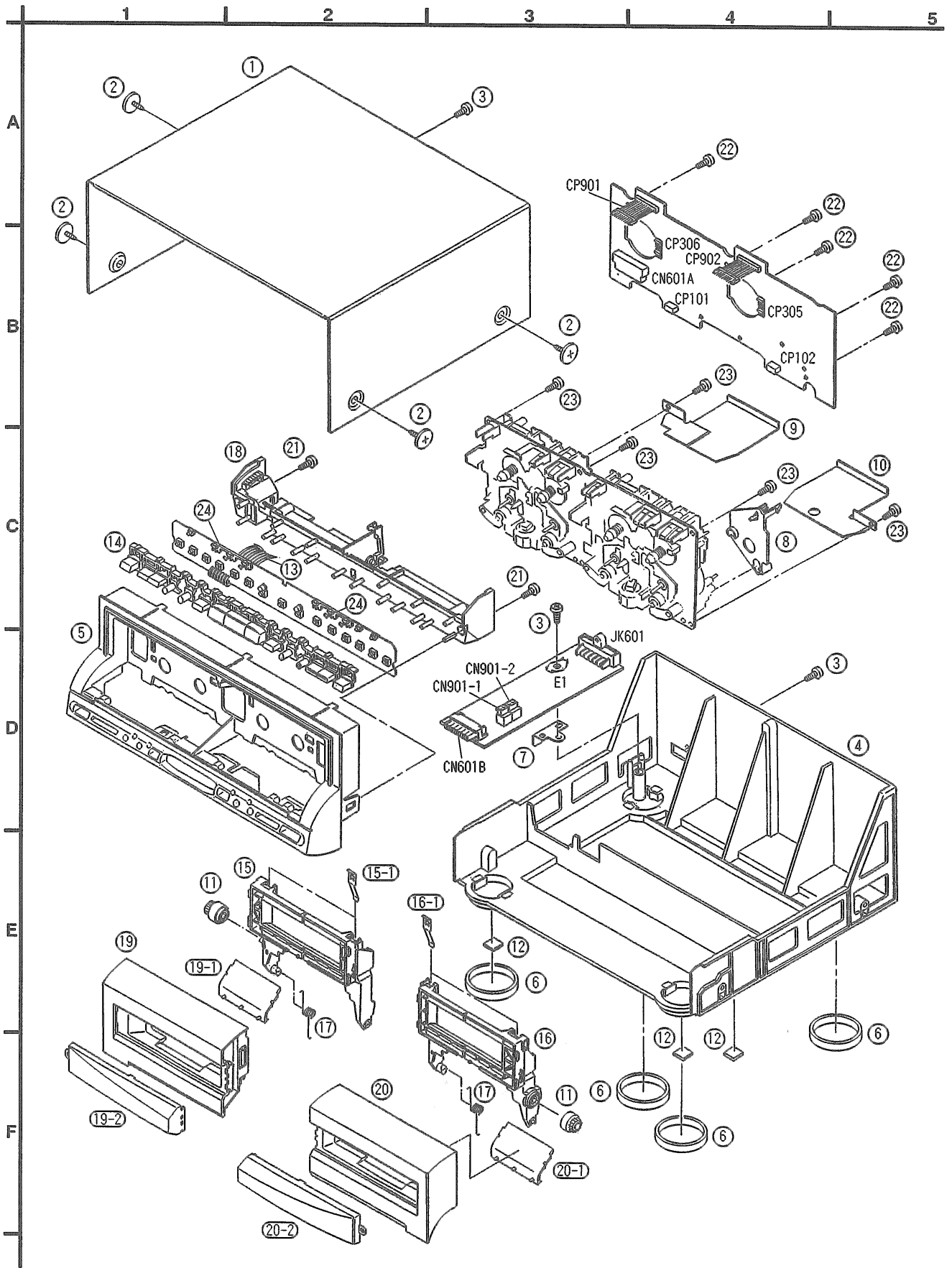

# Mechanism Parts Location

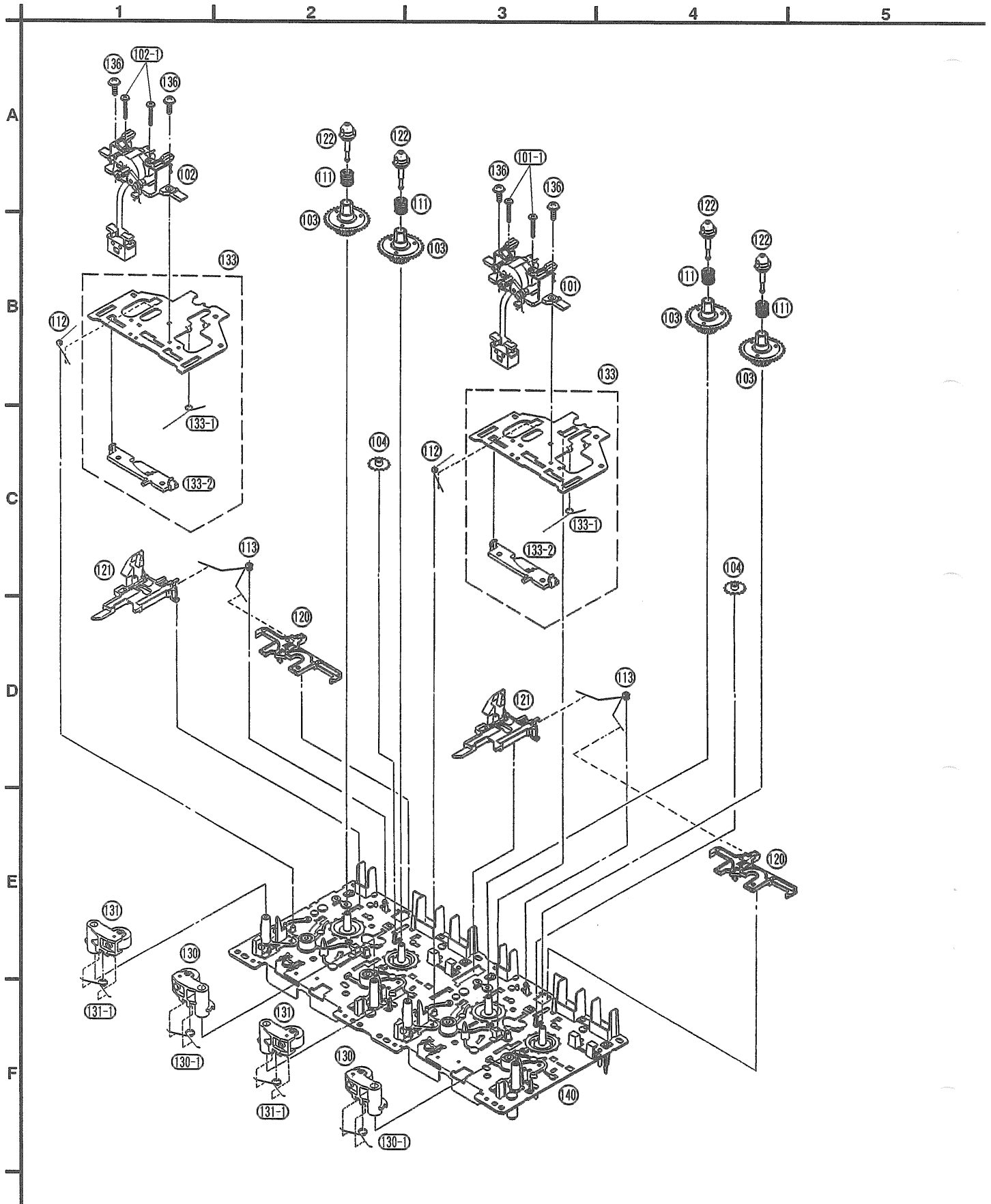

6

7

8

9

